



**Beta**

**Action**

**2017**

**Promozione  
valida dal  
16/01/2017  
al 15/12/2017**  
Prezzi netti I.V.A. esclusa

# Arredo officina



 **Beta**  
**R S C 55**

Configura on-line la tua officina

[www.beta-tools.it/RSC55](http://www.beta-tools.it/RSC55)

**360°**  
view





## PAG

31BM/D6	34
32AU	34
42...	20
42INOX /SC9	45
55/SP7	20
88/S7	21
90/S7	20
96/SC9	24
96BPC/SC9	24
96BP-CO /SC9	23
96LBP/SC9	24
96T/S5P	23
97BTX/SC8	24
97TTX/S6	23
111	22
142...	21
186 8-32	41
192/S2	21
336	41
341	41
351C	41
362	42
374	42
388C/C8	42
412/SP19P	37
414/SP19T	37
415CO /SP19A	37
437K/8	66
437C	37
446C/C110	37
599DGT	30
601CA	30
605E	29
606	29
677/C	29
680	30
720...	76-77
860/C27	25
860/58K	25
862F/A7	25
900/58	26
900/C12M	27
900/C12MR	27
900/C39	27
900/C39-R	27
900/C44	25
902A/C22	27
910/58	26
910A/C16MR	28
910A/C16	28
920/58	26
920A/C17M	28
920A/C17MR	28
920/38	26
920/55L	26
928A/C12	28
941/S5	22
951/S6	23
952/D7	22
960AD/TP2	56

960KC-M8/9/10	57
960KPC	57
960/22EP	68
960EPC	57
960P/S	59
961D...	53
971TSP	67
985/B7	66
1009L/DP-S2	31
1031/S4	32
1047	32
1048BM	32
1052	31
1128BAX	35
1149F	43
1169BM/D3	31
1169MQ/D2	44
1203/D...	33
1207TX /D7	33
1243/D7	33
1256/C36-2	43
1257LPH/S8	44
1263/D...	33
1267TX/D7	33
1273MQ/D6	44
1293/D8	33
1293INOX /D8	45
1365/K13	71
1365 P10	71
1366/K5	76
1368	69
1368G/K400	69
1370T	34
1390	34
1392	34
1428/SB11	40
1462/KMRC	59
1462/KU	58
1462AD/BSC	58
1462AD/SMN	59
1462KI	58
1464...	56
1471M/C22	67
1474E/VW	60
1476GT	68
1476PSA	68
1477/C10	60
1478T	68
1480	61
1482...	61-62
1483/K12	67
1494VW	63
1494M	64
1497/C23	52
1497/C94	52
1498	55
1498LT/12	55
1498MN/12	55
1498PC	76
1498ST/TB	54

1498TB/12	54
1498/...A	53-54
1500N	39
1517	39
1529PI	60
1530/C5	66
1535/C	39
1545/C5M	40
1547/C6	40
1550U	70
1566P	66
1567	69
1569/A	65
1569CP	65
1608/C9T	43
1609B	43
1651DGT...	38
1691BM	38
1696B	38
1719BM A8/S5	35
1726BM	35
1740B	46
1741B	46
1749AC	46
1750 500	46
1756C	47
1756D	47
1758LG	64
1758R	64
1759HD/3	61
1760PA/AC-DC	52
1760/RMS	44
1766ER	69
1770A	36
1771BM	36
1772R	36
1778W	36
1778SOS	36
1834P...	49
1836A	49
1837N	49
1837+	50
1838/11LED	51
1838FLASH	50
1842LED...	51
1846LED...	51
1852 R1750	48
1860K/160A	48
1870 20	47
1874 50	47
1877	63
1877 A	63
1878 3	64
1884	65
1901BM/8	83
1901T/10	83
1921I	81
1927SP-AM	77
1927P	78
1927CD/K3	78

1927XM/K5	78
1928CD	79
1928DA	79
1928K4	79
1930A	80
1930HLA	80
1930PA	80
1932B13	81
1933I	82
1937	82
1942A	82
1946C 4,8	81
1949GPE	83
1949M	83
2080/V6	12
2080/V12	12
3002	72
3003	72
3009	71
3025...	75
3026...	75
3027...	74
3030 2T	72
3065/40-20T	73
3067/70-13T	73
5927VU/M	9
5988...	6
5988UX/MP	7
7042LCD	48
7200PN	87
7201PN	87
7208WR	91
7210PB	87
7211PG	87
7220PE	86
7221PE	86
7224PE	86
7235B	85
7236B	85
7241C	84
7243C	84
7243CR	86
7245B	84
7246B	84
7248G	85
7249G	85
7250NKK	89
7251NKK	89
7258NKK	89
7259NKK	89
7313B	88
7313G	88
7316N	88
7320M	88
7340B	91
7340Y	91
7341N	91
7360UN	90
7361UB	90
7368UM	90

7368UN	90
7525	93
7526	93
7815N	92
7816BL	92
7816G	92
7816ST	92
7840BL	93
7849BL	93
7860E	95
7861E	95
7861E	95
7863E	95
7865E	95
7867E	95
7869E	95
7870E	96
7871E	96
7873E	96
7875E	96
7877E	96
7879E	96
7900E	94
7901E	94
7903E	94
7905E	94
7907E	94
7909E	94
C04TSS/7	45
C5	13
C6T	13
C7	13
C8	14
C9	14
C10	15
C10S	14
C11	15
C12	15
CP15...	12
CP17	11
C20L	11
C22P...	11
C23ST	3
C24S...	3
C24SA-XL...	7
C24SL-CAB	4
C27S	9
C28	4
C39...	2
C41H	10
C42H	10
C51	8
CP51	8
C56	8
C59...	5
T10-92	18
T103-239	19
M10-287	16-17

## C39/7

### Cassettiera mobile con 7 cassetti

da 588x367 mm montati su guide telescopiche a sfera

- Serratura di sicurezza centralizzata frontale
- Piano di lavoro termoplastico
- 4 ruote ø 125 mm 2 fisse e 2 girevoli (1 con freno)
- Portaflaconi laterali e posteriori integrati
- Portacarta integrato
- Piano dei cassetti protetto da tappetini di gomma espansa

039000001

039000002

039000003

~~€ 1.275,00~~ € 710,00

1200 kg



**Struttura in lega di alluminio:  
+ RESISTENZA  
+ LEGGEREZZA**



**Ruote con nucleo in acciaio**

61 kg

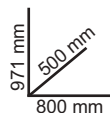

n°	h	max
5	70 mm	30 kg
1	140 mm	35 kg
1	210 mm	35 kg

## C39/6

### Cassettiera mobile con 6 cassetti

039000031

039000032

039000033

~~€ 1.205,00~~ € 670,00

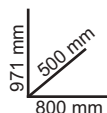

59 kg

n°	h	max
4	70 mm	30 kg
1	140 mm	35 kg
1	280 mm	40 kg

## C39/8

### Cassettiera mobile con 8 cassetti

039000041

039000042

039000043

~~€ 1.360,00~~ € 755,00



64 kg

n°	h	max
6	70 mm	30 kg
2	140 mm	35 kg

## C39T

### Cassettiera portatile con 4 cassetti

da 588x367 mm, montati su guide telescopiche a sfera

039000101

039000102

039000103

~~€ 810,00~~ € 455,00

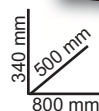

29 kg

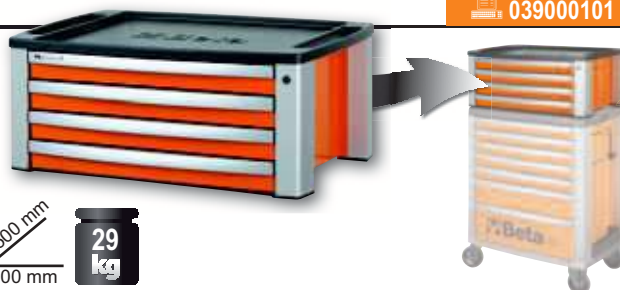

n°	h	max
4	70 mm	30 kg





## C24S/7

### Cassettiera mobile con 7 cassetti

da 588x367 montati su guide telescopiche a sfera

- Piano di lavoro in ABS ad alta resistenza
- Serratura di sicurezza centralizzata frontale
- 4 ruote Ø 125 mm 2 fisse e 2 girevoli (1 con freno)
- Portaflaconi laterale integrato
- Piano dei cassetti protetto da tappetini di gomma espansa

024002071

024002072

024002073

800 kg

~~€ 735,00~~ € 417,00



Frontalino in Nylon ad alta resistenza



Ruote con nucleo in acciaio

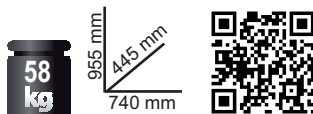

n°	h	max
5	70 mm	25 kg
1	140 mm	30 kg
1	210 mm	30 kg



## C24S/6

### Cassettiera mobile con 6 cassetti



024002061

024002062

024002063

~~€ 680,00~~ € 382,00

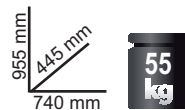

55 kg

n°	h	max
4	70 mm	25 kg
1	140 mm	30 kg
1	280 mm	35 kg



## C24S/8

### Cassettiera mobile con 8 cassetti



024002081

024002082

024002083

~~€ 793,00~~ € 452,00

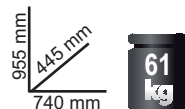

61 kg

n°	h	max
6	70 mm	25 kg
2	140 mm	30 kg



## C23ST

### Cassettiera portatile con 5 cassetti

da 588x367 mm, montati su guide telescopiche a sfera

- Serratura centralizzata frontale
- Kit opzionale 4 ruote + maniglione (2300ST/KIT)



023000521

023000522

023000523

~~€ 505,00~~ € 289,00

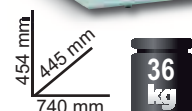

36 kg

n°	h	max
5	70 mm	25 kg



## C24SL-CAB **Novità**

### Cassettiera mobile con 7 cassetti e armadietto portaoggetti

- Sette cassetti da 588x367 mm, montati su guide telescopiche a sfera
- Piano dei cassetti protetto da tappetini di gomma espansa.
- Quattro ruote Ø 125 mm: 2 fisse e 2 girevoli (2 con freno).
- Serratura centralizzata frontale.
- Armadietto laterale portaoggetti con ripiano interno regolabile in altezza e anta richiudibile con serratura
- Piano di lavoro in legno multistrato con fori per la collocazione di una morsa 1599F/100 da ordinare separatamente.
- Portacarta integrato.
- Doppio portaflaconi posteriore.



1100 kg

024002191

024002192

024002193

€ 1.100,00 € 635,00

n°	h	max
5	70 mm	25 kg
1	140 mm	30 kg
1	210 mm	30 kg

970 mm  
365 mm  
1050 mm

80 kg

## C28

### Carrello SuperTank con piano di lavoro e 10 cassetti

- da 588x367 mm, montati su guide telescopiche a sfera
- Piano di lavoro in legno multistrato con fori per la collocazione di una morsa 1599F/150 da ordinare separatamente
  - Sistema rapido e sicuro per l'apertura e chiusura dei cassetti con frontalino in nylon ad alta resistenza
  - Vano passante altezza 135 mm con base ricoperta in materiale plastico
  - 4 portaflaconi: 2 frontali e 2 posteriori
  - Vano laterale con antina di chiusura a scomparsa con serratura
  - 4 ruote ad alta portata Ø 150 mm: 2 fisse e 2 girevoli con freno
  - 6 vaschette portaminuterie laterali
  - Piano dei cassetti protetto da tappetini di gomma espansa



1200 kg

028000301

028000302

028000303

€ 1.950,00 € 1.125,00

945 mm  
800 mm  
1235 mm

130 kg



n°	h	max
8	70 mm	25 kg
2	210 mm	30 kg





## Banchi da lavoro "Endurance"

- Ripiano in legno multistrato con fori per la collocazione di una morsa 1599F/125 (da ordinare separatamente).
- Piano dei cassetti protetto da tappetini di gomma espansa.
- Cassettiere predisposte per l'inserimento di termoformati
  - Frontalino dei cassetti in nylon ad alta resistenza
  - Serratura di sicurezza centralizzata frontale.
  - Ripiano inferiore portaoggetti.
- Predisposizione per portacarta (2400S-R/PC) e portafilaconi (2400S/PF) da ordinare separatamente.



### C59A



059000001

059000021

059000041

**Banco con 1 cassettera da 6 cassetti.**

- 6 cassetti 588x367 mm, montati su guide telescopiche a sfera

~~€ 1.265,00~~ € 720,00

1500 kg

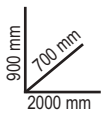

115 kg

n°	h	max
4	70 mm	25 kg
1	140 mm	30 kg
1	280 mm	35 kg

### C59B



059000002

059000022

059000042

**Banco con 2 cassettere da 6 cassetti.**

- 12 cassetti 588x367 mm, montati su guide telescopiche a sfera

~~€ 1.710,00~~ € 980,00

1500 kg

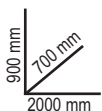

155 kg

n°	h	max
8	70 mm	25 kg
2	140 mm	30 kg
2	280 mm	35 kg



## 5988U/MP



SOFT  
MODULE  
SYSTEM

L 059880528 XL 059880529

Assortimento di 91 utensili, in termoformato morbido

~~€ 1.015,00~~ € 585,00



M15 M33 M199 M202



M50 M83



M132 M153 M234 M145



## 5988 U6/MP



SOFT  
MODULE  
SYSTEM

L 059880530 XL 059880531

Assortimento di 214 utensili, in termoformato morbido

~~€ 2.390,00~~ € 1.385,00

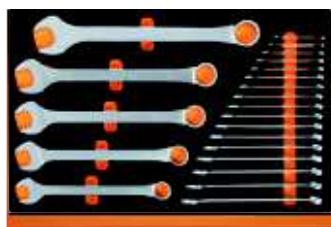

M10



M30



M210

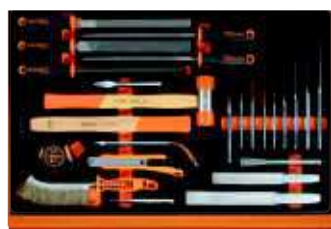

M230



M130

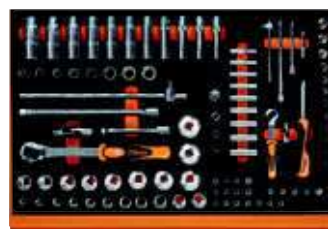

M100



## 5988VA/T Novità



L 059880510 XL 059880511

Assortimento di 102 utensili, in termoformato rigido

~~€ 1.320,00~~ € 760,00



T199 T202 T83



T145 T153 T131 T234

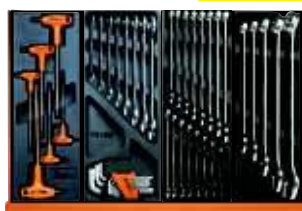

T52 T33 T15 T16



T63 VP5



## 5988VI/T Novità



L 059880520 XL 059880521

Assortimento di 104 utensili, in termoformato rigido

~~€ 1.295,00~~ € 746,00



T199 T202 T83



T145 T153 T131 T234

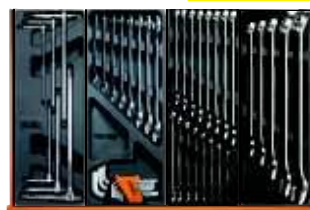

T68 T33 T15 T16



T287





## C24SA-XL/7

**Cassettiera mobile con 7 cassetti con sistema antiribaltamento, modello lungo**

- 7 cassetti da 882x367 mm, montati su guide telescopiche a sfera
- Piano di lavoro in ABS ad alta resistenza, con 6 vaschette portaminuterie
- Frontalino in nylon ad alta resistenza, con porta-etichette integrato
- Piano dei cassetti protetto da tappetini di gomma espansa
- 4 ruote con nucleo in acciaio Ø 125 mm: 2 fisse e 2 girevoli (1 con freno)
- Serratura di sicurezza centralizzata frontale
- Portaflaconi laterale integrato

024002271

024002272

024002273

~~€ 968,00~~ € 551,00

1000 kg



Frontalino in Nylon ad alta resistenza

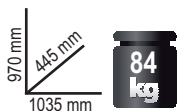

n°	h	max
5	70 mm	30 kg
1	140 mm	35 kg
1	210 mm	35 kg

può contenere 6 TERMOFORMATI



## C24SA-XL/8

**Cassettiera mobile con 8 cassetti con sistema antiribaltamento, modello lungo**

024002281

024002282

024002283

~~€ 1.045,00~~ € 596,00

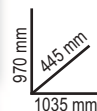

n°	h	max
6	70 mm	30 kg
2	140 mm	35 kg



## 5988 UX/MP Novità

Assortimento di 135 utensili in termoformato morbido per cassettiera C24SA-XL



L 059880540

XL 059880541

~~€ 1.510,00~~ € 870,00



M16 M15 M33 M145 M131



M50 M55 M153 M199 M202



M234 M236 M83 M289 M91



## C56

### Banco da lavoro

- Piano di lavoro in lamiera verniciata con bordo perimetrale
- Struttura in acciaio con 6 gambe di sostegno
- Abbinabile alla parete C57P (non fissabile al piano di lavoro)
- Due cassetti dotati di serratura
- Predisposizione per il fissaggio al pavimento

930 mm  
640 mm  
2000 mm



056000201

056000202

056000203

1200 kg

~~€ 705,00~~ € 405,00

## CP51 Novità

### Carrello ad alta resistenza

- 2 ripiani ricoperti da tappetini in gomma
- Maniglia ergonomica
- Quattro ruote Ø 125 mm ad alta resistenza: 2 fisse e 2 girevoli con freno.
- Capacità di carico statico: 750 kg. (distribuita sui 2 ripiani)

900 mm  
600 mm  
900 mm

37 kg



051000501

051000502

051000503

750 kg

~~€ 260,00~~ € 149,00



## C51

### Carrello

- 3 ripiani ricoperti in gomma millerighe antiscivolo
- Capacità di carico statico: 200 kg (distribuito su 3 ripiani)
- Doppia possibilità di fissaggio del ripiano centrale
- 4 ruote Ø 100 mm: 2 fisse e 2 girevoli (1 con freno)

21 kg

900 mm  
450 mm  
800 mm



051000001

051000002

051000003

200 kg

~~€ 200,00~~ € 113,00



## C27S



027000201

027000202

027000203

**Carrello portautensili richiudibile per interventi esterni, vuoto**

~~€ 510,00~~ **€ 293,00**

- Struttura in lamiera
- Carrello richiudibile con colonnine ribaltabili per permettere un agevole trasporto
- 2 cassette 588x277 mm montate su guide telescopiche che permettono l'apertura in due sensi
- Ampio vano portaoggetti inferiore 588x277x220 mm
- 2 ruote fisse Ø 160 mm e 2 ruote piroettanti con freno Ø 100 mm
- Piano di lavoro termoplastico con 6 vaschette portaminuterie integrate
- Chiusura centralizzata.
- Predisposizione per l'alloggiamento di separatori per cassetto e termoformati portautensili MC



**Trasportabile su veicolo**



**Novità**

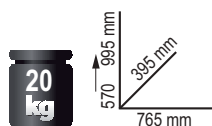

n°	h	max
2	70 mm	20 kg



**20 kg**



## 5927VU/M



059270021

**Assortimento di 108 utensili in termoformato morbido per carrello C27S**

~~€ 779,00~~ **€ 450,00**

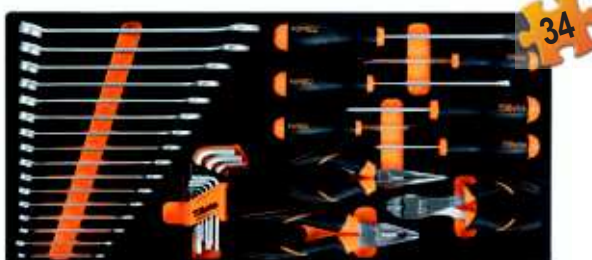

**MC10**



**MC20**



## C41H

041000002

041000010

041000008

~~€ 432,00~~ € 245,00

### Trolley portautensili a 2 moduli in lamiera d'acciaio

- 2 moduli separabili:
  - 1 cestello superiore,
  - 1 modulo con 2 cassette altezza 95 mm,
  - 1 cassetta portautensili estraibile in materiale plastico altezza 66 mm e 1 cassetto altezza 295 mm
- Portaminuterie integrato
- Impugnatura con manico telescopico in alluminio
- Predisposizione per lucchetto
- Serratura centralizzata per il modulo inferiore
- Cassetto inferiore con doppia guida telescopica
- Ruote di grosso diametro  $\varnothing$  160 mm



Novità



21 kg

825 mm  
335 mm  
536 mm



## C42H

042000002

~~€ 310,00~~ € 175,00

### Trolley portautensili a 3 moduli sovrapponibili

- 3 moduli separabili:
  - 1 cestello superiore, altezza 220 mm
  - 1 modulo portautensili centrale, altezza 180 mm
  - 1 modulo portautensili inferiore con ruote, altezza 330 mm
- Può essere utilizzato solamente con 2 moduli



Ruote di grosso diametro ( $\varnothing$  160 mm)



Cestello superiore con vano portaoggetti interno e 3 portaminuterie integrati nel coperchio



Manico telescopico regolabile in 3 posizioni.



Sistema di sgancio rapido dei moduli: agevole e veloce accesso a tutti i diversi scomparti portautensili.

14 kg

730 mm  
345 mm  
545 mm



**Struttura in lamiera e materiale plastico**



## C22P

**Baule portautensili da cantiere, in lamiera**

- Maniglie incassate a scomparsa
- Pattini rialzati per il sollevamento con muletto
- Doppia chiusura anti-effrazione per lucchetto (non incluso)



### C22PM

022000240

915x540x430 mm

~~€ 475,00~~ € 275,00

### C22PL

022000245

1220x720x615mm

~~€ 740,00~~ € 429,00



## C20L

021200002

**Cestello estendibile a 5 scomparti, vuoto in lamiera**

~~€ 62,50~~ € 36,00

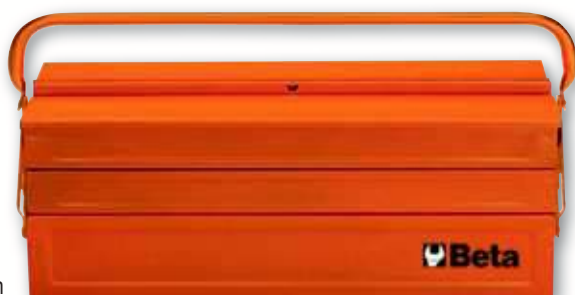

550x200x210 mm



## CP17

021170500

**Cestelli portautensili in acciaio inox e materiale plastico con contenitore asportabile, vuoto**

~~€ 64,00~~ € 37,00

500x200x220 mm



## 2080/V12

Valigia organizer con 12 vaschette asportabili



020800000

~~€ 43,50~~ € 25,00

300x330x145 mm



Vaschette portaminuterie asportabili, richiudibili e trasparenti per un' immediata riconoscibilità del contenuto.

## 2080/V6 Novità

Valigia organizer con 6 vaschette asportabili e divisori regolabili



020800060

~~€ 28,00~~ € 16,00

385x320x60 mm



Possono essere agganciate alla cintura

## CP15

Cestello in materiale plastico con contenitore e vaschette portaminuterie asportabili, vuoto

- 1 vaschetta portaminuterie integrata nel coperchio
- 2 vaschette portaminuterie asportabili con divisori regolabili
- 1 contenitore interno con divisori regolabili
- Portata massima: 30 kg

021150201

~~€ 35,00~~ € 20,00



445x240x250 mm



## CP15L

Cestello modello lungo in materiale plastico con contenitore e vaschette portaminuterie, vuoto

- 3 vaschette portaminuterie integrate nel coperchio con divisori regolabili
- 1 contenitore interno con divisori regolabili
- Portata massima: 30 kg

021150202

~~€ 46,50~~ € 27,00



558x277x270 mm



## C5

02105000

### Zaino portautensili in tessuto tecnico, vuoto

- Pannello portautensili interno removibile
- 6 tasche esterne
- 2 capienti tasche interne
- Base in materiale plastico resistente all'acqua
- Doppio laccetto di sicurezza per fissare lo zaino sulle spalle

~~€ 114,00~~ € 65,00



500x400x180 mm



## C6T

02106010

### Zaino portautensili in tessuto tecnico con ruote, vuoto

- Manico telescopico di trasporto
- Ruote integrate nella struttura con copertura anti-polvere per l'impiego come zaino
- 2 pannelli portautensili removibili
- 5 tasche esterne
- Capiente tasca interna porta pc

~~€ 162,00~~ € 93,00

480x370x220 mm



## C7

02107000

### Borsa portautensili in tessuto tecnico, vuota

- 2 pannelli interni portautensili removibili
- Tasca porta PC interna
- 2 tasche esterne frontali
- Fondo interno in materiale plastico con divisori removibili

~~€ 172,00~~ € 99,00

440x370x170 mm



## C9

021090000

### Borsa portautensili in tessuto tecnico, vuota

- Base rigida
- Pratiche tasche interne ed esterne
- Tasca esterna con chiusura a zip
- Doppio fondo
- Doppio laccio per livelle

~~€ 89,00~~ € 51,00

≡ 550x200x210 mm



## C8

021080000

### Trolley portautensili in tessuto tecnico, vuoto

- Manico telescopico di trasporto
- 2 pannelli interni portautensili, removibili
- 2 tasche esterne frontali
- Tasca porta pc interna
- Predisposizione per l'alloggiamento del cestello C10S (da ordinare separatamente)

~~€ 189,00~~ € 108,00

≡ 470x370x280 mm



## C10S

021100001

### Cestello portautensili in tessuto tecnico, vuoto

- Struttura rigida
- Doppio fondo. Il fondo si può rimuovere per aumentare la capienza della borsa
- Manico inclinabile per facilitare l'accesso agli utensili
- Elastici portautensili e tasche sia interne che esterne
- Fodero di copertura
- Vaschetta portaminuterie inclusa nel doppio fondo

~~€ 88,00~~ € 50,50

≡ 420x220x250 mm





## C10

02110000

### Cestello portautensili in tessuto tecnico, vuoto

- Struttura rigida
- Doppio fondo. Il fondo si può rimuovere per aumentare la capienza della borsa
- Manico inclinabile per facilitare l'accesso agli utensili
- Elastici portautensili e tasche sia interne che esterne
- Fodero di copertura
- Vaschetta portaminuterie inclusa nel doppio fondo

~~€ 114,00~~ € 65,00



520x220x250 mm

## C11

021110000

### Cestello portautensili in tessuto tecnico, vuoto

- Base rigida in materiale plastico resistente all'acqua
- Elastici e tasche portautensili sia interne che esterne
- Buste portadocumenti integrate nel doppiofondo del coperchio

~~€ 67,00~~ € 38,50



400x240x220 mm



## C12

021120000

### Borsa portautensili per elettricisti in tessuto tecnico, vuota

- Pannello interno portautensili estraibile
- Elastici portautensili e capienti tasche sia interne che esterne
- Base rigida impermeabile con piedini in gomma
- Predisposizione per essere utilizzata con il trolley C8

~~€ 148,00~~ € 86,00

500x370x270 mm



**La borsa si apre anteriormente per facilitare l'accesso agli utensili sul luogo di lavoro**

## M10

024500010

~~€ 339,00~~ € 196,00

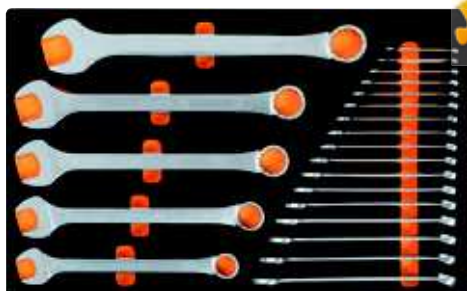

22

42 6-7-8-9-10-11-12-13-14-15-16-17-18-19-20-21-22-24-27-30-32-36 mm

## M30

024500030

~~€ 308,00~~ € 178,00



31

55 6x7-8x9-10x11-12x13-14x15-16x17-18x19-20x22  
21x23-24x27-30x32 mm  
90 6x7-8x9-10x11-12x13-14x15-16x17-18x19-20x22  
21x23-24x27-30x32 mm  
96BPC/SC9 1,5-2-2,5-3-4-5-6-8-10 mm

## M60

024500060

~~€ 289,00~~ € 167,00



24

○ 96T 2-2,5-3-4-5-6-7-8-10 mm  
○ 97BTX/SC8 T9-T10-T15-T20-T25-T27-T30-T40  
○ 944BX 5-6-7-8-10-13 mm

## M63

024500063

~~€ 258,00~~ € 149,00



8

○ 952 7-8-10-12-13-14-17-19 mm

## M100 12" 14"

024500100

~~€ 961,00~~ € 557,00

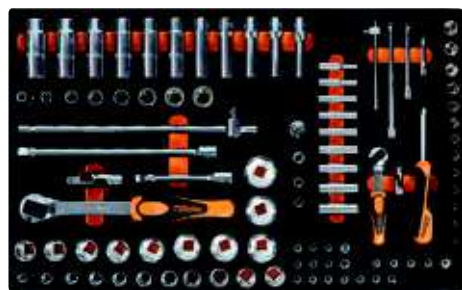

98

895/1 - 895/3 - 895/6  
○ 900 4-4,5-5-5,5-6-7-8-9-10-11-12-13-14 mm  
○ 900L 5-6-7-8-9-10-11-12-13 mm  
○ 900ME 3-4-5-6-7 mm  
○ 900LP 0,8x4-1x5,5-1,2x6,5-1,2x8 mm  
⊕ 900PH PH1-PH2-PH3-PH4  
○ 900TX T10-T15-T20-T25-T27-T30-T40  
900/20 50 mm - 900/20L 100 mm  
900/21 150 mm  
900/25 - 900BG/30 - 900/42  
⊕ 900/55  
○ 920A 8-10-11-12-13-14-15-16-17-18-19-20-21-22-23-24-26-27-28-30-32 mm  
920/15 - 920/25  
920AN/125 125 mm  
920AN/250 250 mm  
920/42  
⊕ 920/55  
○ 920FTX 10-12-14-16-18-20-22-24 mm  
○ 920AL 10-12-13-14-15-16-17-18-19-21-22 mm

## M120 12"

024500120

~~€ 1.032,00~~ € 598,00

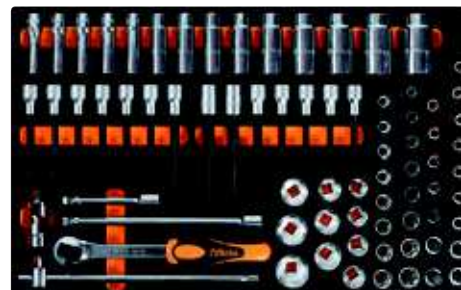

75

○ 920A 10-11-12-13-14-15-16-17-18-19-20-21-22-24-26-27-30-32 mm  
920AN/125 125 mm  
920AN/250 250 mm  
920/25 - 920/42  
○ 920AL 10-12-13-14-15-16-17-18-19-22-24-27-30-32 mm  
⊕ 920FTX 10-12-14-16-18-20-22-24 mm  
⊕ 920/55  
○ 920PE 5-5L-6-6L-7-7L-8-8L-10-10L-12-12L-14-14L  
○ 920TX T20-T25-T27-T30-T40-T45-T50-T55-T60-T20L-T25L-T27L-T30L-T40L-T45L-T50L



# Termoformati morbidi

## M121 <sup>12</sup>

024500121

~~€ 944,00~~ € 547,00

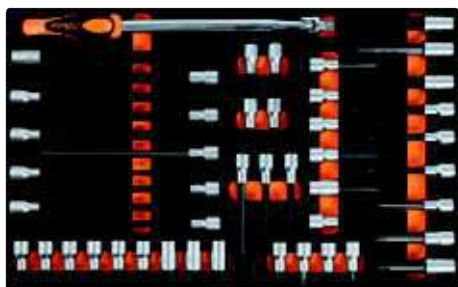

46

- 920BP 5L-6L-8L-10L-5XL-12L-14L-14L-16-18 mm
- 920TX T20-T25-T27-T30-T40-T45L-T50L-T55L-T60L-T70L
- 920XZN 4-5-6-6L-8-8L-10-10L-12-12L-14XL-16XL mm
- 920ES 7-9-10-11-12L-14L-16L-7XL-9XL-10XL-11XL-12XL-14XL-16XL mm
- 920/36A

## M130

024500130

~~€ 320,00~~ € 185,00



13

- 1032 180 mm
- 1034 170 mm
- 1036 175 mm
- 1038 175 mm
- 1048 250 mm
- 1052 240 mm
- ‡ 1082BM 160 mm
- 1098 220 mm
- 1112 250 mm
- 1128BM
- 1150BM 180 mm
- 1166BM 160 mm
- 1168BM 160 mm

## M210

024500210

~~€ 157,50~~ € 91,00

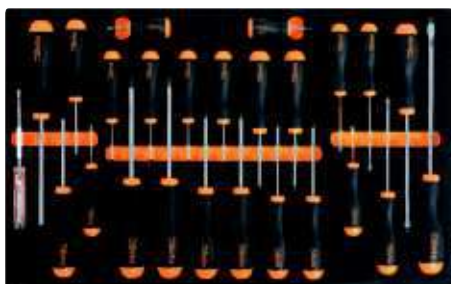

25

- 1201 2,5x50-3x75-4x100-5,5x125-6,5x150-8x200 mm
- 1201N 4x30 mm
- 1202 PH0x60-PH1x80-PH2x100-PH3x150 mm
- 1202N PH1X30 mm
- 1207TX T6-T7-T8-T9-T10-T15-T20-T25-T27-T30-T40-T45
- 1253

## M230

024500230

~~€ 303,00~~ € 175,00



25

- 30 Ø 2-3-4 mm
- 31 Ø 2-3-4-5-6-8 mm
- 32 Ø 4 mm
- 34 150 mm
- 35 200-250 mm
- 36 125 mm
- 1370 500 g
- 1390 Ø 35 mm
- 1692 3 m
- 1712
- 1719BMA/Q 200 mm
- ▲ 1719BMA/T 200 mm
- 1719BMA/P 200 mm
- ▶ 1719BMA/M 200 mm
- 1719BMA/R 200 mm
- 1737
- 1771 18 mm

## M65

024500065

~~€ 394,00~~ € 228,00

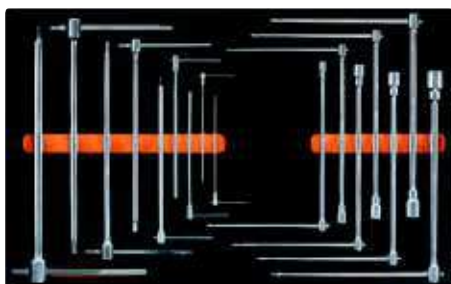

16

- 950 8-10-12-13-14-17-19 mm
- 951 2,5-3-4-5-6-8-10-12-14 mm

## M287

024500287

~~€ 184,50~~ € 107,00



9

- 1128BMX
- 1130BMX
- 1719BMA/Q 200 mm
- 1719BMA/P 200 mm
- ▶ 1719BMA/M 200 mm
- 1719BMA/R 200 mm
- 1726BM 400 mm
- 1728BM
- 1771BM 170 mm
- 1778 185 mm

**T10** 024240010

~~€ 206,50~~ € 119,50



42 6-7-8-10-11-12-13-14  
16-17-18-19-21-22-24-27-30 mm

**T15** 024240015

~~€ 157,50~~ € 91,00



42 6-7-8-9-10-11-12-13-14  
15-16-17-18-19-20-21 mm

**T16** 024240016

~~€ 111,50~~ € 64,50



42 22-24-27-30-32 mm

**T31** 024240031

~~€ 166,50~~ € 96,50



31 Ø 2-3-4-5-6 mm  
32 Ø 4 mm  
55 6x7-8x9-10x11-12x13-14x15-16x17-18x19  
20x22-21x23-24x26-27x29-30x32 mm  
○ 96N/SC9 1,5+10 mm

**T40** 024240040

~~€ 78,50~~ € 45,50



90 6x7-8x9-10x11-12x13  
14x15-16x17-18x19 mm

**T45** 024240045

~~€ 238,50~~ € 138,00



142 8-9-10-11-12-13-14  
15-16-17-18-19 mm

**T46** 024240046

~~€ 283,00~~ € 164,00



142SN 8-9-10-11-12-13-14  
15-16-17-18-19 mm

**T50** 024240050

~~€ 131,50~~ € 76,00



○ 96T 2-2,5-3-3,5-4-4,5-5-6-7-8-10 mm

**T55** 024240055

~~€ 74,00~~ € 42,90



○ 97TTX T10-T15-T20 T25-T27-T30

**T63** 024240063

~~€ 252,00~~ € 146,00



○ 952 7-8-10-12-13-14-17-19 mm

**T83** 024240083

~~€ 263,00~~ € 152,50



12" ○ 920A 10-11-12  
13-14-15-16-17-18  
19-20-21-22-23-24  
26-27-30-32 mm  
920/21 125 mm  
920/22 255 mm  
920/25  
920/42 305 mm  
920/55 275 mm

**T85** 024240085

~~€ 266,00~~ € 154,00



14" 81  
○ 861LP 0,5x3-0,6x4,5-0,8x5,5-1x5,5  
1,2x6,5-1,2x8-1,6x8 mm  
○ 861PE 2-2,5-3-4-5-6-8-10 mm  
○ 861PH PH0- PH1 - PH2 - PH3  
○ 861PZ PZ1 - PZ2 - PZ3  
○ 861TX T6-T7-T8-T9-T10-T15-T20-T25  
T27-T30-T40  
○ 861RTX T9-T10-T15-T20-T25-T27-T30-T40  
○ 861TRW 1-2-3-4-5-6 mm  
○ 861TQS 0-1-2-3-4-5-6-8 mm  
○ 861SP 4-6-8-10-12 mm  
851SR 230 mm  
○ 900 4-4,5-5-5,5-6-7-8-9-10-11-12-13-14 mm  
900/21 150 mm 900/25 41 mm  
900BG/30 176 mm 900/42 115 mm  
○ 900/55 125 mm 194 1/4x5/16

**T91** 024240091

~~€ 175,50~~ € 101,50



14" 25  
○ 900 4-4,5-5-5,5-6  
7-8-9-10-11-12  
13-14 mm  
○ 900ME 2,5-3-4-5-6-8 mm  
900/20 50 mm  
900/21 150 mm  
900/25  
900BG/30 176 mm  
900/42 115 mm  
○ 900/55 125 mm

**T92** 024240092

~~€ 211,00~~ € 122,00



38" 22  
○ 910A 6-7-8-9-10-11-12  
13-14-15-16-17-18  
19-20-21-22 mm  
910/21 125 mm  
910/22 250 mm  
910/25  
910/42 210 mm  
○ 910/55 200 mm



**T103**

024240103

~~€ 237,50~~ € 137,50

12" 14"

- 900L 6-7-8-9-10-11-12 mm
- 920AL 13-14-16-17-18-19  
21-22-24-27 mm

**T131**

024240131

~~€ 83,50~~ € 48,20

- 1084BM 160 mm
- 1150BM 180 mm
- 1166BM 160 mm

**T145**

024240145

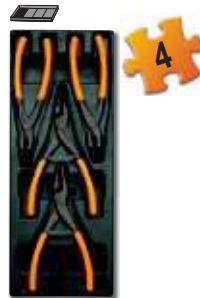
~~€ 93,00~~ € 53,50

- ⊙ 1032 180 mm
- ⊙ 1034 170 mm
- 1036 175 mm
- 1038 175 mm

**T153**

024240153

~~€ 58,00~~ € 33,50

- 1048 250 mm
- 1052 240 mm

**T199**

024240199

~~€ 42,50~~ € 24,50

- 1260 2,5x50 - 3x75  
3,5x100 - 4x125 - 5,5x100  
5,5x150-6,5x150 mm

**T202**

024240202

~~€ 39,50~~ € 22,90

- ⊕ 1262 PH0x60 - PH0x100 - PH1x80  
PH1x120 - PH2x100 - PH2x150 mm

**T205**

024240205

~~€ 58,50~~ € 33,90

- ⊙ 1267TX  
T6-T7-T8-T9-T10-T15-T20

**T210**

024240210

~~€ 30,50~~ € 17,50

- 1201 2,5x50-3x75-3,5x100-  
4x125- 5,5x100-5,5x150 6,5x150mm

**T212**

024240212

~~€ 32,50~~ € 18,80

- ⊕ 1202 PH0x60-PH1x80  
PH1x120-PH2x100  
PH2x150-PH3x150 mm

**T215**

024240215

~~€ 44,00~~ € 25,50

- ⊙ 1207TX  
T6-T7-T8-T9-T10-T15-T20

**T234**

024240234

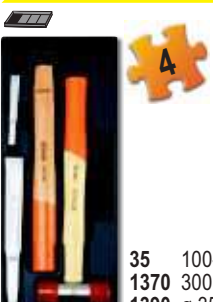
~~€ 71,00~~ € 41,00

- 35 100-200 mm
- 1370 300 g
- 1390 ø 35 mm

**T236**

024240236

~~€ 70,00~~ € 40,50

- 1719BMA/Q 200 mm
- ▲ 1719BMA/T 200 mm
- ▨ 1719BMA/P 200 mm
- ▤ 1719BMA/M 200 mm
- 1719BMA/R 200 mm

**T239**

024240239

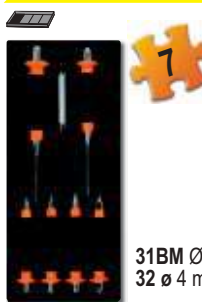
~~€ 95,50~~ € 55,00

- 31BM Ø 2-3-4-5-6-8 mm
- 32 ø 4 mm

## 42/SP15

Serie di 15 chiavi combinate  
con supporto

6-7-8-9-10-11-12-13-14-15  
16-17-19-22-24 mm



000420078

~~€ 143,00~~ € 81,00



## 55/SP7

Serie di 7 chiavi a forchetta doppie  
con supporto

6x7-8x9-10x11-12x13-14x15  
16x17-18x19 mm



000550167

~~€ 40,00~~ € 23,00



## 42/SC9I

Serie di 9 chiavi combinate  
con supporto compatto

8-10-11-12-13-14-15-17-19 mm



000420087

~~€ 84,50~~ € 48,50



## 90/S7

Serie di 7 chiavi poligonali  
doppie curve

6x7-8x9-10x11-12x13-14x15-16x17-18x19 mm



000900163

~~€ 70,50~~ € 40,50





## 142/SC9I

Serie di 9 chiavi combinate a cricchetto reversibile con supporto compatto

8-10-11-12-13-14-15-17-19 mm



001420087

~~€ 170,00~~ € 98,00

## 142SN/SC9

Serie di 9 chiavi combinate a cricchetto snodate con supporto compatto

8-10-11-12-13-14-15-17-19 mm



001420259

~~€ 203,00~~ € 117,00

## 192/S2

Serie di 2 chiavi poligonali a cricchetto reversibile



001920070

~~€ 51,50~~ € 29,80

8 misure in 2 chiavi



## 88/S7 Novità

Serie di 7 chiavi poligonali doppie diritte extralunghe

8x10-12x14-13x15-16x18-17x19-21x23-22x24 mm

000880107

~~€ 155,50~~ € 89,00

# EXTRALUNGHE



## 142C/A12

Serie di 12 chiavi combinate corte diritte a cricchetto in astuccio

8-9-10-11-12-13-14-15-16-17-18-19 mm

001420175

~~€ 174,50~~ € 99,50



# 111

## Chiavi regolabili a rullino cromate con scala graduata

- Apertura della ganascia mobile con rotazione destrorsa del rullino
- Scala millimetrata e in pollici



## Doppia lettura mm - pollici

	L mm	A max.		€
<b>111/150</b>	150	24 mm	001110015	<del>€ 19,50</del> € 11,00
<b>111/200</b>	200	28 mm	001110020	<del>€ 23,50</del> € 13,50
<b>111/250</b>	250	34 mm	001110025	<del>€ 29,00</del> € 16,70
<b>111/300</b>	300	35 mm	001110030	<del>€ 39,00</del> € 22,50

# 941/S5

Serie di 5 chiavi a pipa esagonali-poligonali con impugnatura di manovra

○ 7-8-10-12-13 mm

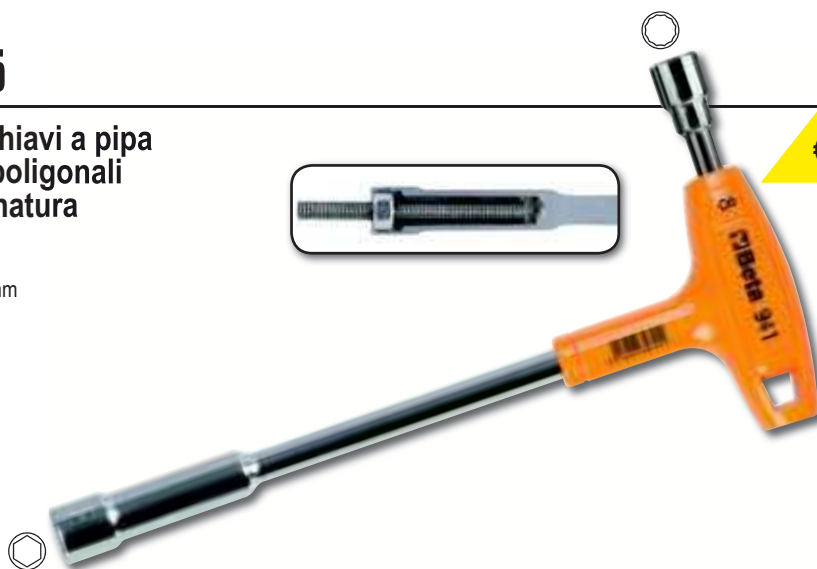

009410150

~~€ 120,50~~ € 69,00



# 952/D7

Serie di 7 chiavi a T con bussola esagonale snodata

○ 7-8-10-12-13-14-17 mm

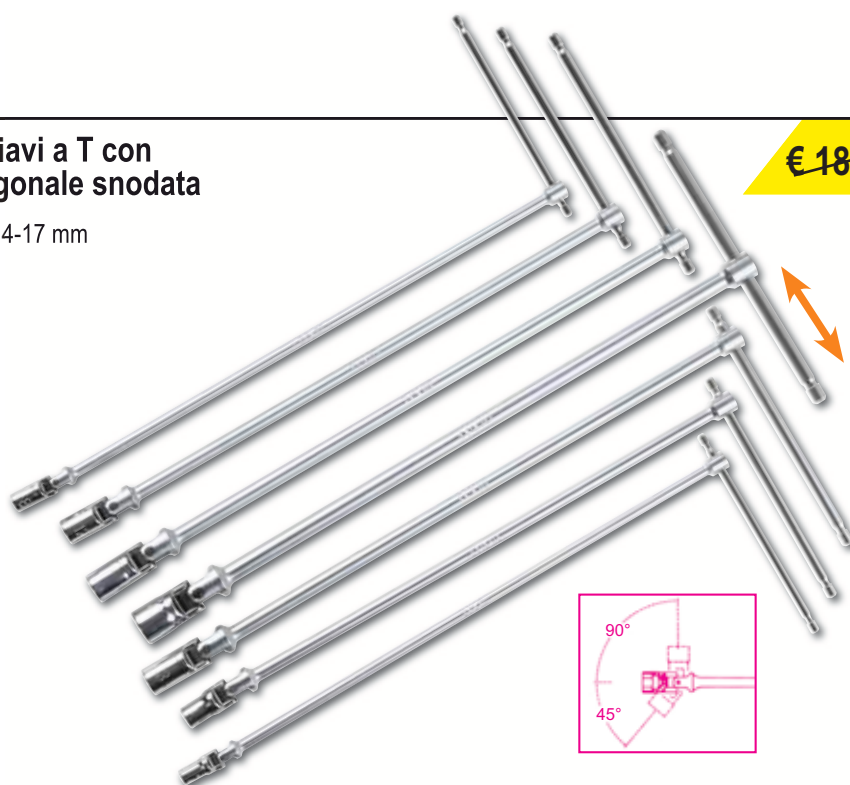

009520079

~~€ 188,00~~ € 108,00





# Chiavi maschio

## 96T/S5P



Serie di 5 chiavi maschio esagonale piegate con impugnatura

○ 2,5-3-4-5-6 mm



000960946

~~€ 49,00~~ € 28,00



## 951/S6



Serie di 6 chiavi a T con tre estremità maschio esagonale

○ 2,5-3-4-5-6-8 mm



0009510687

~~€ 98,00~~ € 56,00



## 97TTX/S6



Serie di 6 chiavi maschio piegate per viti con impronta Torx® con impugnatura

○ T10-T15-T20-T25-T30-T40



000970795

~~€ 69,00~~ € 39,50

## 96BP-C0/SC9

### Novità

Serie di 9 chiavi maschio esagonale piegate colorate con un'estremità sferica

○ 1,5-2-2,5-3-4-5-6-8-10 mm



# Identifica subito la tua misura!

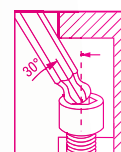

000961519

~~€ 43,00~~ € 24,00

supporto con sistema  
di bloccaggio  
delle chiavi



## 96/SC9



Serie di 9 chiavi maschio esagonale piegate

○ 1,5-2-2,5-3-4-5-6-8-10 mm

000960374

~~€ 15,80~~ € 9,00

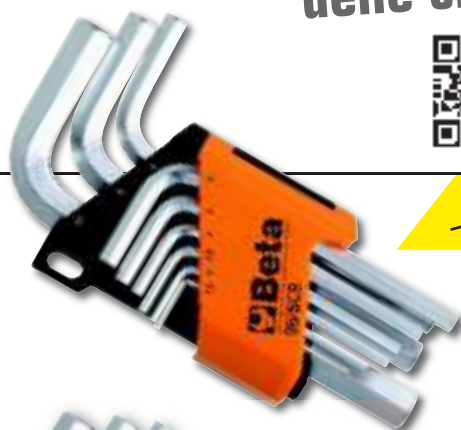

## 96BPC/SC9



Serie di 9 chiavi maschio esagonale piegate con un'estremità sferica

○ 1,5-2-2,5-3-4-5-6-8-10 mm

000960354

~~€ 34,50~~ € 17,20

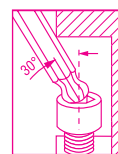

## 96LBP/SC9



Serie di 9 chiavi maschio esagonale piegate con un'estremità sferica

○ 1,5-2-2,5-3-4-5-6-8-10 mm

000961354

~~€ 39,00~~ € 22,00

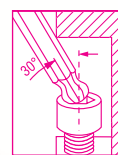

# Modello extra lungo

# + 30%

## 97BTX/SC8



Serie di 8 chiavi maschio piegate con un'estremità sferica per viti con impronta Torx®

○ T9-T10-T15-T20-T25-T27-T30-T40

000970164

~~€ 61,00~~ € 33,00

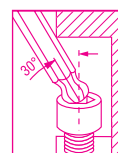
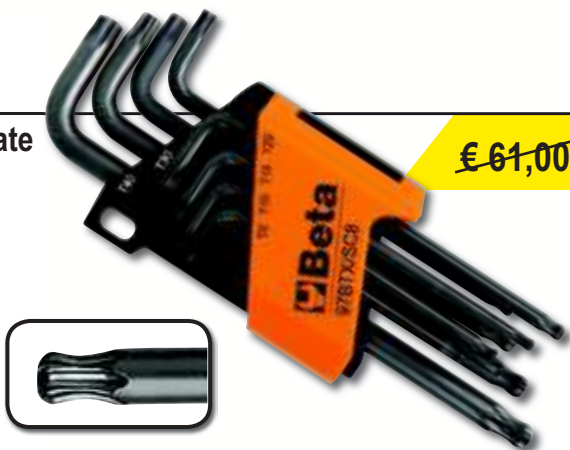



## 860/58K



008609884

Cricchetto portainseri con impugnatura rotante

• Avvicinamento rapido dell'inserto con la sola rotazione dell'impugnatura

~~€ 57,00~~ € 33,00



• L'inserto si può inserire su entrambi i lati per avvitare o svitare



## 860/C27



Serie di 25 inserti colorati con raccordo e cricchetto reversibile in astuccio tascabile

- 860LP 0,5x3-1,0x5,5-1,2x6,5 mm
- 860PE 2-2,5-3-4-5-6-mm
- ⊕ 860PH PH1-PH2(x2)-PH3
- ⊗ 860TX T6-T8-T10-T15-T20-T25-T30-T40
- ⊕ 860PZ PZ1 - PZ2(2x) - PZ3
- 860/55 100 mm
- 892/0

Cricchetto interamente in acciaio



008600880

~~€ 68,00~~ € 39,00

## 862F/A7



Serie di 7 inserti a bussola esagonale magnetici, in astuccio tascabile

- 862F 5,5-6-7-8-10-12-13 mm



008620950

~~€ 38,00~~ € 22,00

## 900/C44 Novità



009000942

Assortimento di 13 chiavi a bussola esagonali, 28 inserti per avvitatori e 3 accessori, in cassetta di lamiera

~~€ 134,50~~ € 77,50

Nuovo quadro con impugnatura

	900	○ 4-4,5-5-5,5-6-7-8-9-10-11-12-13-14 mm
	900/25	
	900T/44	238 mm
	895/1	○ 1/4" - □ 1/4"
	861LP	● 0,5-0,8-1,0-1,2 mm
	861PE	○ 2-2,5-3-4-5-6-8-10 mm
	861PH	⊕ PH0-PH1-PH2-PH3-PH4
	861PZ	⊕ PZ1-PZ2-PZ3-PZ4
	861TX	⊗ T8-T10-T15-T20-T25-T30-T40

350x150x50 mm



## 920/55L Novità 12"

009200927

Cricchetto estensibile reversibile con attacco quadro maschio 1/2" meccanismo a 72 denti

- Sistema di blocco dell'impugnatura

~~€ 82,00~~ € 47,00



7 differenti lunghezze  
Da 280 a 422 mm

Estensibile fino al 70%  
in più rispetto allo standard



## 920/38 Novità 12"

009200839

Quadro estensibile maschio 1/2" snodato con impugnatura

- Testa snodata a 180°
- Sistema di blocco dell'impugnatura

~~€ 67,00~~ € 39,00



7 differenti lunghezze  
PER ARRIVARE  
OVUNQUE SERVA

14" 38" 12"

Cricchetto reversibile con impugnatura rotante

- Sistema di inversione a ghiera sulla testa del cricchetto
- Impugnatura bimatériale



Avvicinamento  
rapido del quadro  
con la sola rotazione  
dell'impugnatura

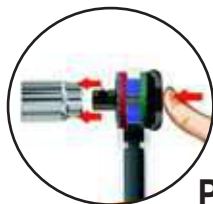

Pulsante di rilascio  
della bussola

A mm

∅ mm

	L mm	∅ mm	A mm	■		€
900/58	126	28	28,5	1/4"	009000884	<del>€ 55,50</del> € 32,00
910/58	222	37	38,5	3/8"	009100884	<del>€ 60,50</del> € 35,00
920/58	281	42,5	45	1/2"	009200926	<del>€ 71,00</del> € 40,50





# Chiavi a bussola



150x95x50 mm

	861LP	0,6x4,5-1,2x6,5-1,2x8 mm
	861PE	2,5-3-4-5-6 mm
	861PH	PH1-PH2-PH3
	861PZ	PZ1-PZ2-PZ3
	861RTX	T10-T15-T20-T25-T27-T30-T40 mm
	892/0	1/4" - 1/4"
	895/1	1/4" - 1/4"
	900	5-5,5-6-7-8-9-10-11-12-13-14 mm
	900/20	50 mm
	900/20L	100 mm
	900/25	
	900BG/30C	

Assortimento di 11 chiavi a bussola esagonali, 21 inserti e 7 accessori in cassetta di plastica



**900/C39**

009000937

~~€ 158,50~~ € 91,00



con cricchetto reversibile (900/55)

**900/C39-R**

009000938

~~€ 180,00~~ € 101,00



con cricchetto reversibile manico rotante (900/58)



350x150x50 mm

	861LP	0,5x3-0,8x5,5-1x5,5-1,2x6,5 mm
	861PE	3-4-5-6-8 mm
	861PH	PH0-PH1-PH2-PH3
	861TX	T8-T10-T15-T20-T25-T30-T40
	895/1	1/4" - 1/4"
	900	4-5-5,5-6-7-8-9-10-11-12-13-14 mm
	900/20	50 mm
	900/21	150 mm
	900/25	
	900/42	
	900BG/30	



Assortimento di 12 chiavi a bussola esagonali, 20 inserti per avvitatori e 7 accessori in termoformato morbido, in cassetta di lamiera



**900/C12M**

009000963

~~€ 174,50~~ € 101,00



con cricchetto reversibile (900/55)

**900/C12MR**

009000962

~~€ 193,00~~ € 111,00



con cricchetto reversibile manico rotante (900/58)



**902A/C22**



Assortimento di 22 chiavi a bussola esagonali e 6 accessori in cassetta di lamiera

009020807

<b>1/4"</b>		900	5-5,5-6-7-8-9-10-11-12-13 mm
		900/20	50 mm
		900/25	
		900/55	
<b>1/2"</b>		920A	10-13-14-15-17-18-19-22-24-27-30-32 mm
		920/21	125 mm
		920/25	
		920/55	

~~€ 288,00~~ € 165,00



420x185x60 mm



≡ 335x145x60 mm

	910A	○	6-7-8-9-10-11-12-13-14 15-16-17-18-19-21-22 mm
	910/21		125 mm
	910/22		250 mm
	910/25		
	910/42		

**3/8"**

Assortimento di 16 chiavi a bussola esagonali e 5 accessori in cassetta di lamiera



**910A/C16** 009100936

~~€ 214,50~~ € 122,00



con cricchetto reversibile (910/55)

**910A/C16HR** 009100935

~~€ 234,50~~ € 132,00



con cricchetto reversibile manico rotante (910/58)



≡ 420x185x60 mm

	920A	○	10-11-12-13-14-15-16-17-18-19 20-21-22-24-27-30-32 mm
	920/21		125 mm
	920/22		255 mm
	920/25		
	920/42		

**1/2"**

Assortimento di 17 chiavi a bussola esagonali e 5 accessori in termoformato morbido, in cassetta di lamiera



**920A/C17M** 009200924

~~€ 259,00~~ € 149,00



con cricchetto reversibile (920/55)

**920A/C17MR** 009200937

~~€ 281,00~~ € 159,00



con cricchetto reversibile manico rotante (920/58)



**928A/C12** **3/4"**

009280955

Assortimento di 12 chiavi a bussola esagonali e 5 accessori in cassetta di lamiera

	928A	○	22-24-27-30-32-34-36-38-41 46-50-55 mm
	928/21		200 mm
	928/22		380 mm
	928/25		
	928/42		
	928/55	⊗	

≡ 530x220x80 mm

~~€ 634,00~~ € 365,00





## 605E **Novità**

**1/4"**

Chiavi dinamometriche a scatto con cricchetto reversibile per serraggi destrorsi e sinistrorsi precisione  $\pm 6\%$



UNI EN 26789 ISO 6789



### 605E/5

006050105

~~€ 160,00~~ € 93,00

Nm	Kgfm	lbf.ft	■	L mm	g
1÷5	0,1÷0,5	10÷45	1/4	190	180

### 605E/10

006050110

~~€ 170,00~~ € 99,00

Nm	Kgfm	lbf.ft	■	L mm	g
2÷10	0,2÷1,0	18÷90	1/4	190	180

## 606 **3/8"** **1/2"**

Chiavi dinamometriche a scatto con cricchetto reversibile per serraggi destrorsi precisione  $\pm 4\%$



UNI EN 26789 ISO 6789



	Nm	lbf.ft	■	L mm	g		€
<b>606/6</b>	8÷60	6÷44	3/8"	305	595	006060105	<del>€ 175,00</del> € 100,50
<b>606/10X</b>	20÷100	15÷80	1/2"	345	680	006060111	<del>€ 181,00</del> € 104,50
<b>606/20</b>	40÷200	30÷150	1/2"	440	920	006060120	<del>€ 193,00</del> € 111,50
<b>606/30</b>	68÷330	40÷250	1/2"	560	1180	006060130	<del>€ 220,00</del> € 126,50

## 677/C **3/4"**

Chiave dinamometrica a disinnesto con cricchetto semplice per serraggi destrorsi e sinistrorsi precisione  $\pm 4\%$  in cassetta



UNI EN 26789 ISO 6789

677/C100

	Nm	lbf.ft	■	L mm	kg		€
<b>677/C50</b>	100÷500	70÷350	3/4"	915	5,2	006770606	<del>€ 720,00</del> € 420,00
<b>677/C70</b>	150÷700	100÷500	3/4"	1140	6,2	006770611	<del>€ 750,00</del> € 435,00
<b>677/C100</b>	300÷1000	200÷750	3/4"	1470	7,5	006770615	<del>€ 883,00</del> € 515,00



# 599DGT



**Chiave dinamometrica elettronica a lettura diretta per serraggi destrorsi ( $\pm 2\%$ ) e sinistrorsi ( $\pm 3\%$ )**

- Cricchetto reversibile:
- Display LCD
- Unità di misura: Nm, ft.lb, in.lb, kgcm:
- Doppia segnalazione, acustica e visiva
- Alimentazione: 2 batterie AA 1,5V incluse



UNI EN 26789 ISO 6789

	Nm	Kgfm	lbf.ft	■	L mm	g	PC	€
<b>599DGT/6</b>	12÷60	1,2÷6	8÷44	3/8"	413	900	005990003	<del>€ 298,00</del> € 170,00
<b>599DGT/10X</b>	20÷100	2÷10	15÷80	1/2"	413	910	005990010	<del>€ 308,00</del> € 176,00
<b>599DGT/20</b>	40÷200	4÷20	30÷150	1/2"	520	2000	005990020	<del>€ 328,00</del> € 189,00
<b>599DGT/30</b>	68÷340	6,8÷34	58÷280	1/2"	539	2350	005990030	<del>€ 358,00</del> € 205,00

# 680



**Misuratore di coppia elettronica digitale**

- Permette la verifica della taratura delle chiavi dinamometriche, funzionamento destrorso e sinistrorso
- Precisione di lettura:  $\pm 1\%$  del valore letto
- Display 4 digit
- Dotato uscita RS232 per collegamento e trasmissione dati a PC

Novità	Nm	kg	PC	€
<b>680/2,5</b>	1÷25	2,6	006800002	<del>€ 1.650,00</del> € 955,00
<b>680/40</b>	15÷400	4	006800040	<del>€ 1.695,00</del> € 985,00
<b>680/100</b>	100÷1000	4,8	006800100	<del>€ 2.350,00</del> € 1.365,00



# 601CA Novità



006010120

~~€ 295,00~~ € 170,00

**Goniometro digitale per serraggi coppia ed angolo**

- Permette serraggi coppia ed angolo
- Per serraggi destrorsi e sinistrorsi
- Precisione coppia:  $\pm 4\%$  del valore impostato
- Precisione angolo:  $\pm 2\%$
- Modalità di misurazione: picco/traccia
- Scala di lettura in Nm/ft.lb/in.lb/kg.cm/gradi
- Dotato di avvisatore acustico (BUZZER) e avvisatori luminosi (LED) che segnalano l'avvicinamento e il raggiungimento dell'angolo o della coppia impostati
- 9 valori di coppia o angolo preimpostabili
- 50 misurazioni memorizzabili
- Fornito in custodia di ABS con certificato di taratura
- Alimentazione: 2 batterie AAA (incluse)



120x90x120 mm

□ 1/2"	■ 1/2"	Nm 10-200	0-360°	240 g
--------	--------	-----------	--------	-------



## 1169BM/D3

011690123

Assortimento di 1 pinza universale,  
1 pinza becchi mezzotondi lunghi  
e 1 tronchese

~~€ 73,50~~ € 42,50



## 1009L/DP-S2

010090060

Serie di 2 pinze a becchi mezzotondi  
lunghissimi zigrinati con doppio snodo

~~€ 53,00~~ € 30,50

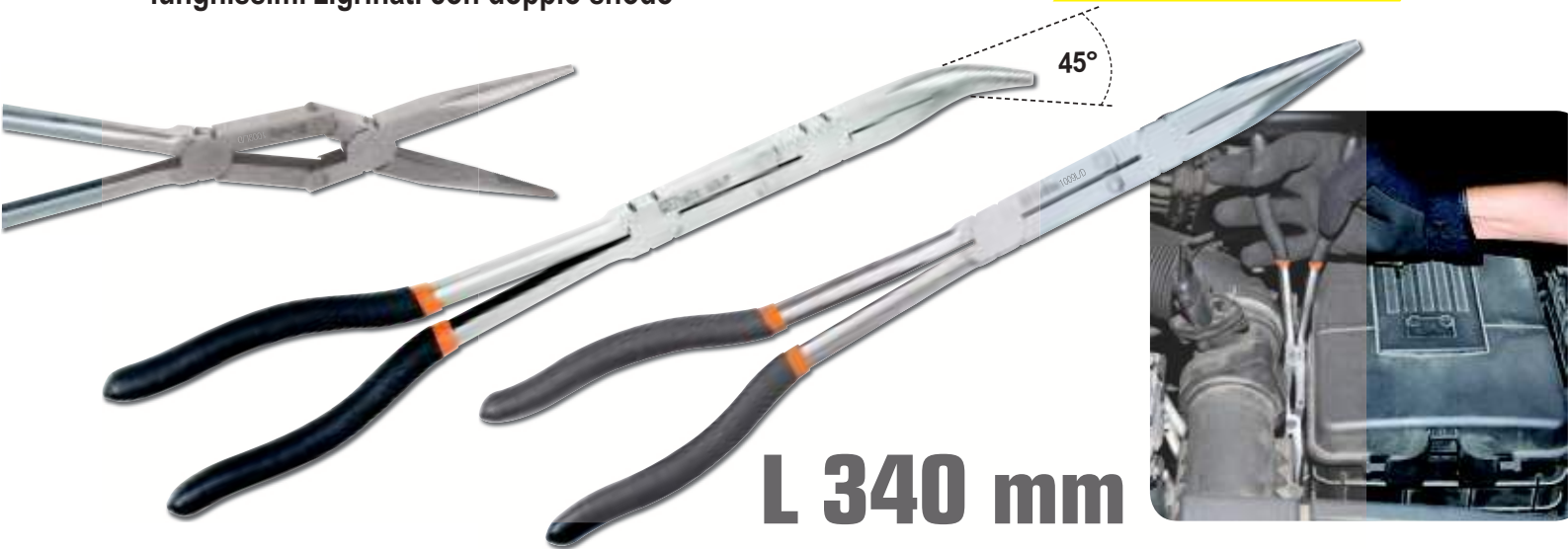

L 340 mm

## 1052

Pinze regolabili  
autobloccanti  
ganasce concave

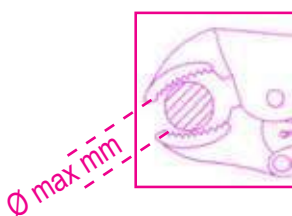

	L mm	Ø Max mm		€
1052/140	140	22	010520014	<del>€ 20,60</del> € 11,90
1052/190	190	36	010520019	<del>€ 23,20</del> € 13,50
1052/240	240	42	010520024	<del>€ 24,70</del> € 14,50

## 1047/240

010470240

### Pinza regolabile a pulsante

- Regolazione rapida e precisa mediante la pressione del pulsante
- Nessuno spostamento accidentale della regolazione
- Trattamento termico localizzato sulle ganasce

~~€ 35,50~~ € 20,50



L 240 mm    ø Max 36 mm    Max 32 mm



## 1048BM/250

010480215

### Pinza regolabile a cerniera chiusa con impugnatura bimatateriale

~~€ 35,00~~ € 20,00



L 250 mm    ø Max 50 mm    Max 48 mm



# 9 posizioni

## 1031/S4

010310000

### Serie di 4 pinze per anelli elastici di sicurezza

~~€ 84,50~~ € 48,50



1036 175 mm  
● 19 ÷ 60 mm

1038 175 mm  
● 19 ÷ 60 mm

1034 170 mm  
○ 19 ÷ 60 mm

1032 180 mm  
○ 19 ÷ 60 mm





Serie di 8 giravite

## 1203/D8P

012030018

~~€ 31,50~~ € 18,00



- 1201 ● 2,5x50-3x75-4x100  
5,5x100-6,5x150 mm
- 1202 ⊕ PH0x60-PH1x80  
PH2x100 mm



Serie di 10 giravite

## 1203/D10N

012030019

~~€ 40,00~~ € 23,00



- 1201 ● 2,5x50-3x75-4x100  
5,5x150-6,5x150 mm
- 1202 ⊕ PH0x60-PH1x80  
PH2x100 mm
- 1201N ● 4x30 mm
- 1202N ⊕ PH1x30 mm

Serie di 7 giravite

## 1207TX/D7

012070207

~~€ 42,00~~ € 24,00



1207TX ⊕ T6-T8-T10-T15-T20-T25-T30



Serie di 8 giravite

## 1263/D8

012630008

~~€ 43,50~~ € 25,00



- 1260 ● 2,5x50-3x75-4x100  
5,5x125-6,5x150 mm
- 1262 ⊕ PH0x60-PH1x80  
PH2x100 mm



Serie di 10 giravite

## 1263/D10

012630010

~~€ 56,00~~ € 32,00



- 1260 ● 3x75-3,5x100-4x125  
5,5x150-6,5x150 mm
- 1262 ⊕ PH0x60- PH1x80  
PH2x100 mm
- 1260N ● 4x30 mm
- 1262N ⊕ PH1x30 mm

Serie di 7 giravite

## 1267TX/D7

012670307

~~€ 57,00~~ € 32,80



1267TX ⊕ T6-T8-T10-T15-T20-T25-T30



## 1293/D8



012930403

Serie di 8 giravite

- 1291 ● 3x75-4x100-5,5x100  
6,5x150-8x150 mm
- 1292 ⊕ PH0x60-PH1x80-PH2x100 mm



~~€ 61,00~~ € 35,20



## 1243/D7



012430017

Serie di 7 giravite a batteria

- 1241 ● 5,5x100-6,5x125-8x150-10x200 mm
- 1242 ⊕ PH1x100-PH2x100-PH3x150 mm

~~€ 75,00~~ € 43,50



## 31BM/D6

Serie di 6 cacciaspina con impugnatura

Ø 2-3-4-5-6-8 mm



000310420

~~€ 80,50~~ € 47,00

## 32AU

Bulino automatico con corpo brunito

- Forza d'urto regolabile fino a 50 Kg
- Utilizzabile con una sola mano



000320160

~~€ 42,50~~ € 25,00

L 150 mm

## 1370T

Martelli tipo tedesco con manico in fibra di vetro



	g		€
1370T/200	200	013700620	<del>€ 15,90</del> € 9,20
1370T/300	300	013700630	<del>€ 17,50</del> € 10,10
1370T/500	500	013700650	<del>€ 18,50</del> € 10,70
1370T/800	800	013700680	<del>€ 20,10</del> € 11,70
1370T/1000	1000	013700700	<del>€ 25,50</del> € 14,80
1370T/1500	1500	013700750	<del>€ 31,00</del> € 17,90

## 1390

Mazzuole con battenti intercambiabili in materiale plastico manico in legno



	Ø mm		€
1390/22	22	013900022	<del>€ 14,00</del> € 8,10
1390/28	28	013900028	<del>€ 17,50</del> € 10,10
1390/35	35	013900035	<del>€ 23,40</del> € 13,50
1390/45	45	013900045	<del>€ 38,00</del> € 22,00
1390/60	60	013900060	<del>€ 64,50</del> € 37,50

## 1392

Mazzuole antirimbalo con battenti intercambiabili in materiale plastico manico in acciaio



	Ø mm		€
1392/30	30	013920030	<del>€ 37,00</del> € 21,50
1392/35	35	013920035	<del>€ 39,00</del> € 22,50
1392/40	40	013920040	<del>€ 44,50</del> € 25,50
1392/50	50	013920050	<del>€ 53,50</del> € 31,00
1392/60	60	013920060	<del>€ 81,50</del> € 47,00



## 1128BAX

011280088

Forbici per elettricisti a doppio effetto, con profili a fresa in acciaio inossidabile rivestito in DLC

~~€ 24,00~~ € 13,80



+ durezza  
- coefficiente d'attrito

### Rivestimento DLC:

Il DLC (diamond-like carbon) è un rivestimento innovativo a base di carbonio: l'elevata durezza ed il basso coefficiente d'attrito nascono dalla simultanea presenza di carbonio depositato sulla superficie in forma di Grafite e Diamante.



- Alta durezza superficiale delle lame (resistenza all'abrasione e mantenimento dell'affilatura nel tempo)
- Basso coefficiente di attrito (scorrevolezza e potenza di taglio)
- Fornite con custodia plastica snodata

### Profilo a fresa:

studiato per allargare fori su particolari in plastica da 13 a 25 mm.

## Taglio a doppio effetto: - SFORZO + POTENZA

una speciale camma sul fulcro riduce del 20% lo sforzo di taglio



• Manici ampi con gole strozzatubi



## 1726BM

017260050

Seghetto con sistema di tensionamento della lama a sgancio rapido

~~€ 36,00~~ € 20,90

- Struttura robusta per maggiore stabilità
- Impugnatura antiscivolo
- Sgancio lama rapido a leva
- Lama inclinabile a 45°
- Design ergonomico



## 1719BMA8/S5

017190070

Serie di lime a taglio mezzodolce impugnatura in materiale plastico

~~€ 63,00~~ € 36,50

## 1778W

017780025

Coltello a serramanico lama in acciaio inossidabile impugnatura con inserti in legno in astuccio

~~€ 27,00~~ € 15,50



## 1778SOS

017780080

Coltello soccorso auto con funzione martello frangicristallo ① e tagliacinture di sicurezza ② in astuccio

~~€ 25,50~~ € 15,00



Impugnatura in alluminio anodizzato

## 1772R

017720006

Cutter 18 mm a lama trapezoidale retrattile, fornito con 5 lame

- Serbatoio portalama interno
- Clip per cintura
- Struttura robusta in alluminio
- Caricamento automatico della lama

~~€ 13,50~~ € 7,70



## 1771BM

017710050

Cutter 18 mm fornito con 6 lame

- Impugnatura bimateriale antiscivolo
- Caricamento automatico della lama
- Ghiera bloccalama per la massima stabilità della lama sotto sforzo
- Corsore di sicurezza antiritorno

~~€ 16,30~~ € 9,20



## 1770A

017700025

Cutter 9 mm con blocco automatico della lama, fornito con 3 lame

- Clip per taschino
- Corsore di sicurezza antiritorno

~~€ 4,75~~ € 2,70





## 412/SP19P 004120429

~~€ 49,50~~ € 29,00

Serie di 19 punte elicoidali cilindriche, in acciaio HSS, rettificate lucide

Ø 1÷10 x 0,5 mm  
 115x170x40 mm



## 415CO/SP19A 004150440

~~€ 105,00~~ € 61,00

Serie di 19 punte elicoidali cilindriche, in acciaio HSS-CO 5%  
 • Per forare acciaio INOX, acciai legati, ghisa, acciai dolci, leghe leggere

Ø 1÷10 x 0,5 mm  
 115x170x40 mm



## Novità

## 414/SP19T 004140440

~~€ 122,00~~ € 70,50

Punte elicoidali cilindriche  
 punte elicoidali cilindriche  
 punte elicoidali cilindriche

Ø 1÷10 x 0,5 mm  
 115x170x40 mm



## 437C 004370100

~~€ 90,50~~ € 52,50

Set ripristino filettature candela danneggiata M14x1,25 mm

• altezza elicoidi:  
 8,40 - 12,40 - 16,40 mm  
 ( 5 pz per misura )



**doppio spessore di titanio = maggiore durata**







## 446/C110

 004460060

Assortimento di 105 maschi e filiere con 5 accessori in acciaio al cromo, filettatura metrica in cassetta di legno

~~€ 670,00~~ € 385,00

 III 430 M mm	 II 433 M mm	 I 440/440A M mm	 I 441/441A M mm
2x0,4	6x0,75 - 7x0,75	2x0,4	6x0,75 - 7x0,75
3x0,5	8x0,75 - 8x1	3x0,5	8x0,75 - 8x1
4x0,7	9x0,75 - 9x1	4x0,7	9x0,75 - 9x1
5x0,8	10x0,75 - 10x1	5x0,8	10x0,75 - 10x1
6x1	10x1,25 - 11x0,75	6x1	10x1,25 - 11x0,75
7x1	11x1 - 11x1,25	7x1	11x1 - 11x1,25
8x1,25	12x0,75 - 12x1	8x1,25	12x0,75 - 12x1
9x1,25	12x1,25 - 12x1,5	9x1,25	12x1,25 - 12x1,5
10x1,5	14x1 - 14x1,25	10x1,5	14x1 - 14x1,25
11x1,5	14x1,5 - 16x1	11x1,5	14x1,5 - 16x1
12x1,75	16x1,5 - 18x1,5	12x1,75	16x1,5 - 18x1,5
14x2		14x2	
16x2		16x2	

435/0 444/1 436/1  
 435/3 444/2



 500x337x60 mm

## 1651DGT

016510111

~~€ 99,50~~ € 58,00

A Max 150 mm  
L 225 mm

Calibro digitale a corsoio in acciaio inossidabile  
temprato in astuccio rigido di materiale plastico

- lettura centesimale
- bloccaggio a vite del corsoio
- conversione mm/pollici



## 1651DGT/200

016510112

~~€ 114,00~~ € 66,00

A Max 200 mm  
L 285 mm

DIN 862 UNI EN ISO 13385-1



## 1691BM Novità

Flessometri cassa bimateriale  
in ABS antiurto nastro in acciaio  
classe di precisione II



	L mm	S mm		€
1691BM/5	5	25	016910205	<del>€ 12,50</del> € 7,00
1691BM/8	8	32	016910208	<del>€ 18,00</del> € 10,00
1691BM/10	10	32	016910210	<del>€ 22,00</del> € 12,50

## 1696B

Livelle con base magnetica in alluminio  
profilato anodizzato  
a 2 file infrangibili



	L mm	H mm	S mm		€
1696B200	200	49	22	016960202	<del>€ 25,00</del> € 14,50
1696B300	300	49	22	016960203	<del>€ 27,00</del> € 15,50
1696B400	400	49	22	016960204	<del>€ 28,50</del> € 16,50



## 1500N

Estrattori universali a 2 griffe scorrevoli autobloccanti

	A min÷Max	Carico Max kg		€
<b>1500N/1</b>	23÷70 mm	6000	015000601	<del>€ 59,00</del> € 34,00
<b>1500N/2</b>	23÷100 mm	6000	015000602	<del>€ 64,00</del> € 37,00
<b>1500N/3</b>	35÷140 mm	10000	015000603	<del>€ 105,00</del> € 61,00
<b>1500N/4</b>	35÷190 mm	10000	015000604	<del>€ 114,00</del> € 66,00

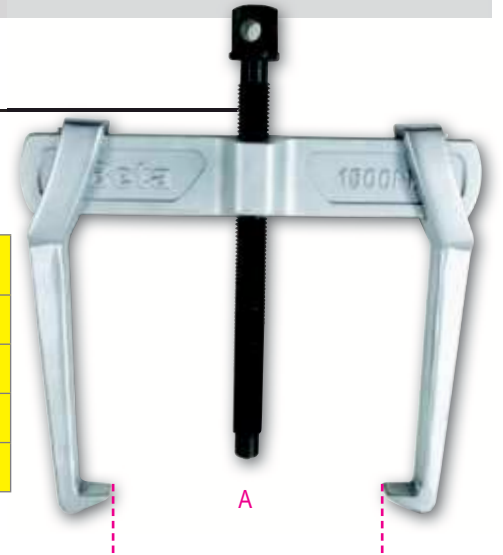

## 1535/C1

015350001

~~€ 229,50~~ € 133,00

	L mm	A min÷Max
<b>1533PR/1</b>	100	
<b>1533/2</b>	150	45÷130 mm
<b>1534/1</b>	88	5÷60 mm

260x180x40 mm



**Estrattori combinati**  
in cassetta di lamiera  
• combinazione di Tiranti 1533, prolunghe 1533PR e Separatori 1534.  
• indicati dove gli estrattori a griffe danneggerebbero il pezzo.



## 1535/C2

015350002

~~€ 242,00~~ € 140,00

	L mm	A min÷Max
<b>1533PR/1</b>	100	
<b>1533/2</b>	150	45÷130 mm
<b>1534/2</b>	118	12÷75 mm

260x180x40 mm

## 1535/C3

015350003

~~€ 425,00~~ € 246,00

	L mm	A min÷Max
<b>1533PR/2</b>	100	
<b>1533/3</b>	210	85÷225 mm
<b>1534/3</b>	160	22÷115 mm

380x280x55 mm

## 1517

Estrattori a 3 griffe autoserranti

- per elevati carichi d' estrazione.
- apertura contemporanea delle griffe.
- effetto autoserrante.
- doppio dado di manovra.
- le misure 90 e 150 sono dotate di una coppia di piattelli per estrazioni su alberi cavi.



	Carico Max kg	A min÷Max	○ mm	● mm		€
<b>1517/90</b>	6000	18÷90 mm	22	19	015170000	<del>€ 190,00</del> € 111,00
<b>1517/150</b>	6000	25÷150 mm	22	19	015170010	<del>€ 205,00</del> € 119,00
<b>1517/200</b>	6000	40÷200 mm	22	19	015170020	<del>€ 235,00</del> € 137,00
<b>1517/260</b>	8000	50÷260 mm	30	27	015170030	<del>€ 265,00</del> € 155,00



# 1547/C6

015470006

## Estrattori per cuscinetti con false sfere

in cassetta di lamiera  
• utilizzabile solo dopo aver "sgabbiato" le sfere.

~~€ 210,50~~ € 122,00

Cuscinetti:  
1547/1  
6011-6014, 6206-6211, 6303-6308, 6403-6405 1  
1547/2  
6004-6010, 6200-6205, 6300-6304



420x185x60 mm



# 1545/C5M

015450011

Estrattore 1542/1 con 5 Espansori 1544 in cassetta di lamiera

~~€ 406,00~~ € 235,00

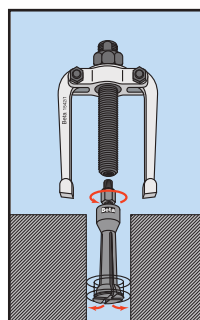

	A mm	C mm
1544/1	9÷12	0,80
1544/2	13÷17	1,15
1544/3	16÷21	1,70
1544/4	20÷25	1,65
1544/5	25÷30	2,00



420x185x60 mm

# 1428/SB11

014280111

Serie di 11 estrattori a bussola per dadi danneggiati con supporto

~~€ 169,50~~ € 98,00



3/8" 8-10-11-12-13-14 mm    1/2" 15-16-17-18-19 mm





**336**

003360001

Tagliatubi ad avanzamento telescopico  
Per rame e leghe leggere

~~€ 39,00~~ € 22,50

Ø 6÷38 mm  
1/4"÷1"1/2



Lama svasatubi estraibile

**341**

003410001

Pinza tagliatubi per tubi  
in materiale plastico

~~€ 27,00~~ € 15,50

Ø 0÷25 mm



**186 8-32** **Novità**

001860008

Chiave autoserrante a ripresa automatica  
per esagoni da 8 a 32 mm

Ideale per viti con testa a profilo: esagonale,  
Spline, quadrato, Torx®; anche rovinate.

~~€ 38,00~~ € 22,00

Rapida  
e polivalente



**Efficace  
anche su viti usurate**



**351C**

003510010

Tagliatubi ed attrezzo bordatubi  
in cassetta di materiale plastico

~~€ 113,00~~ € 65,50



**334** Ø 3÷30 mm  
1/8"÷1"1/8



**350** Ø 4÷14 mm



**351P** Ø 4-4,75-6-8-10-12-14 mm

• L'assortimento di sette puntali  
permette, di realizzare  
una bordatura doppia a 45°

225x150x45 mm

## 388C/C8

Attrezzo curvatubi  
con 7 matrici in alluminio  
per rame ricotto e lega leggera  
in cassetta di plastica



003880200

~~€ 356,00~~ € 205,00

Ø mm 10,12,14,16,18,20,22

400x330x110 mm

## 374

Giratubi modello svedese  
con ganasce sottili a 45°  
in acciaio forgiato



**Robusta struttura nervata  
in acciaio legato per manovre di grande potenza.**

	L mm	Ø Max	Ø Max mm		€
<b>374/320</b>	320	1" gas	34	003740032	<del>€ 38,00</del> € 22,00
<b>374/410</b>	410	1" 1/2 gas	49	003740041	<del>€ 49,50</del> € 29,00
<b>374/550</b>	550	2" gas	60	003740055	<del>€ 79,00</del> € 46,00

## 362

Giratubi modello americano in ghisa malleabile,  
con ganasce in acciaio forgiato



	L mm	Ø Max	Ø Max		€
<b>362/300</b>	300	2" gas	60	003620030	<del>€ 35,50</del> € 20,50
<b>362/350</b>	350	2" gas	60	003620035	<del>€ 43,00</del> € 25,00
<b>362/450</b>	450	2" 1/2 gas	76	003620045	<del>€ 63,00</del> € 36,50
<b>362/600</b>	600	3" gas	90	003620060	<del>€ 94,00</del> € 54,50



## 1149F

011490010

**Pinza spellafili frontale autoregolabile, con dispositivo di taglio**

- Adattamento automatico ai diametri dei conduttori
- Lunghezza della spellatura regolabile
- Regolazione della pressione di taglio isolante
- Dispositivo di taglio integrato



~~€ 12,90~~ € 7,50



0,2÷6 mm<sup>2</sup>  
28÷17 AWG

**Spellature rapide e precise**



## 1608/C9T

016080013

**Pinza per capicorda 1608 con assortimento di 450 capicorda**

~~€ 206,50~~ € 120,00



- |      |  |  |
|------|--|--|
| 1620 |  | 1,5-2,5-6 mm <sup>2</sup><br>50 pezzi per tipo |
| 1624 |  | 1,5-2,5-6 mm <sup>2</sup><br>50 pezzi per tipo |
| 1628 |  | 1,5-2,5-6 mm <sup>2</sup><br>50 pezzi per tipo |



## 1609B

016090101

**Pinza crimpatrice meccanica**

- Per capicorda in rame non isolati da 10 a 120 mm<sup>2</sup>
- Impugnatura in gomma antiscivolo
- Perno interno con sezione ad "H" per la massima scorrevolezza del punzone
- In acciaio brunito

~~€ 238,00~~ € 138,00

**L 600 mm**



10÷120 mm<sup>2</sup>

## 1256/C36-2

012560100

**Microgiravite bimateriale con 36 inserti intercambiabili da 4 mm e prolunga magnetica**

~~€ 51,50~~ € 29,80

	1256TX	⊙	T3-T4-T5-T6-T7-T8-T9-T10-T15
	1256RTX	⊙	T6-T7-T8-T9-T10
	1256LP	●	0,8-1,2-1,5-1,8-2-2,5-3-3,5-4 mm
	1256PE	○	0,7-0,9-1,3-1,5-2 mm
	1256PH	⊕	PH000-PH00-PH0-PH1
	1256PZ	⊕	PZ000-PZ00-PZ0-PZ1
	1256/20		
	1256/30		



**per lavori di precisione**

130x60x35 mm

## 1257LPH/S8



Serie di 8 microgiravite  
Lama Piatta e Phillips®  
in astuccio plastico rigido

- 1257LP: 0.4x2; 0.4x2.5; 0.5x3; 0.6x3.5; 0.8x4mm
- 1257PH: PH00; PH0; PH1

180x117x44 mm



012570210

~~€ 49,50~~ € 28,50

## 1760/RMS



Multimetro digitale industriale preciso e robusto  
in un guscio costampato di 6 mm,  
con gomma esterna antiscivolo ed antiurto

- Protezione dall'acqua IP67
- Ingressi protetti • Autoranging
- Ampio display di immediata lettura, retroilluminato blu
- Sonda temperatura tipo K (inclusa) • Autospegnimento
- Base in gomma portaterminale per un maggiore comfort durante l'uso
- Terminali a doppio isolamento 1000V, lunghezza 1 m
- In custodia morbida • CAT IV 600V/ CAT III 1000V
- Vero valore efficace TRUE RMS

	Campo di misura	Precisione base
Tensione AC/DC	110mV - 600V ±0.8%	- ±2% rdg
Corrente AC/DC	110µA - 10A ±1.5%	- ±2% rdg
Resistenza	110Ω - 40MΩ ±1.2%	- ±2.5% rdg
Capacità	11nF - 40mF ±5%	- ±10% rdg (fino a 11mF)
Frequenza	1100Hz - 110 MHz ±1.2%	- ±1.5% rdg
Temperatura	-32°C - +1000°C ±3%	- ±5% rdg
Test diodi	3V dc ±10% rdg	
Test continuità	<30 Ω	



017600020

~~€ 225,00~~ € 131,00



A prova di  
caduta da 2 m

## 1169MQ/D2

Assortimento di 1 pinza universale isolata  
e 1 tronchese isolato

1082MQ 160 mm

1000 V



1150MQ 180 mm

011690143

~~€ 75,50~~ € 43,50



## 1273MQ/D6



Serie di 6 giravite isolati

1274MQ ●  
3x100-4x100-5,5x125 mm

1000 V

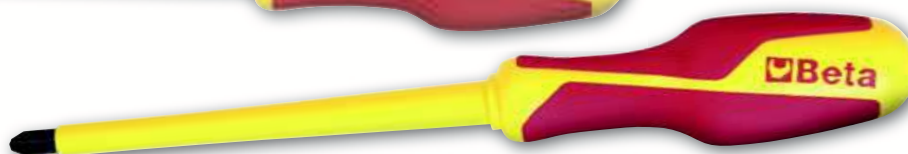
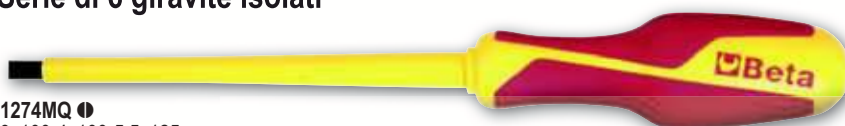

1272MQ ●  
PH0x60-PH1x80-PH2x100 mm

012730851

~~€ 52,50~~ € 30,20





700  
kg



## CO4TSS/7

024003077

Cassettiera mobile  
con 7 cassetti  
completamente in acciaio  
inossidabile

~~€ 1.960,00~~ € 1.130,00

- Sette cassetti da 570 x 410 mm montati su guide telescopiche a sfera; 6 cassetti altezza 83 mm; 1 cassetto altezza 170 mm
- 4 ruote Ø 125mm 2 fisse e 2 girevoli (due con freno)
- Serratura frontale centralizzata
- **Struttura interamente in acciaio inossidabile**
- **Ruote, supporti, sfere, interno dei cassetti e relative guide in acciaio inossidabile**
- Maniglia cassetti in alluminio



83 mm	max 25 kg
170 mm	30 kg

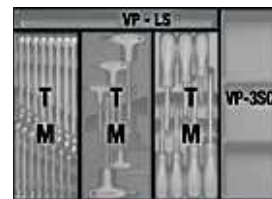
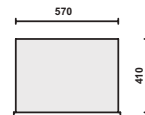

**Gli utensili Beta Inox  
possono essere sterilizzati  
in autoclave a 121°C**

## 42INOX/SC9

000420387

Serie di 9 chiavi combinate  
in acciaio inossidabile  
con supporto compatto

~~€ 142,00~~ € 82,00

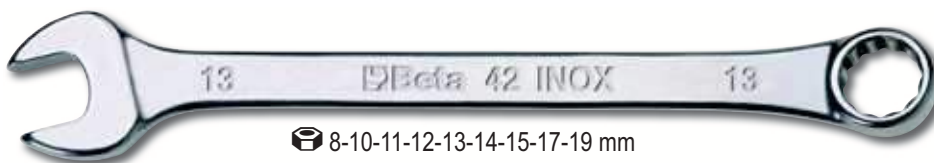

8-10-11-12-13-14-15-17-19 mm



## 1293INOX/D8



012930408

Serie di 8 giravite  
in acciaio inossidabile

~~€ 62,50~~ € 36,50

1290INOX ● 2,5x50-3x75-4x100  
5,5x150-6,5x150 mm



1292INOX ⊕ PH0x60-PH1x80  
PH2x100 mm



## 1740B280

017400280

~~€ 55,00~~ € 32,00

2,4÷4,8 mm acciaio 

## 1740B330

017400330

~~€ 65,00~~ € 37,50

3,2÷6,4 mm acciaio 



**3 griffe:  
migliore presa  
del rivetto**



Serbatoio  
portasteli



### Rivettatrici di potenza compatte

- Rapporto di leva ottimizzato per una maggiore compattezza e praticità d'uso.
- 3 griffe per una presa perfetta del rivetto.
- Testa regolabile per tirare il rivetto da 2 a 5 movimenti dei bracci.

## 1741B

017410000

### Rivettatrice con 4 testine intercambiabili

- rivettatrice con 4 testine intercambiabili
- Struttura in lega leggera



~~€ 30,00~~ € 17,50

## 1749AC

017490005

### Pistola ad alta spinta per ancoranti chimici e cartucce standard



230 mm  
STANDARD Ø 50 mm

~~€ 29,00~~ € 16,90

## 1750 500

017500500

### Compressori a leva per grasso, 500 cc



~~€ 32,00~~ € 18,50

**550 Bar**

## 1756C

017560502

### Siringa per olio da 200 ml in polipropilene

- adatta anche a liquido impianto freni
- doppia guarnizione in EPDM
- temperatura di funzionamento: +0 - +50°C
- NON adatta per carburanti e oli minerali

~~€ 26,00~~ € 15,00



## 1756D

017560515

### Siringa per olio da 1500 ml in polipropilene

- doppia guarnizione in NBR
- temperatura di funzionamento: +0 - +50°C
- NON adatta per carburanti

~~€ 59,00~~ € 34,00



## 1870

018700020

### Aspiratore 20 litri per solidi e liquidi

#### CARATTERISTICHE TECNICHE

- Motore by-pass monostadio
- Tensione 230/240 V
- Frequenza 50/60 Hz
- Potenza Max 1200 W
- Portata d'aria l/sec. 58
- Depressione Max 190 mbar
- Capienza Max bidone 20 l in PP antistatico
- Emissioni acustiche <70 dB(A)
- Lunghezza cavo 5 m

~~€ 169,00~~ € 98,00

**Ruote antitraccia**

20 l



#### ACCESSORI IN DOTAZIONE Ø 36 mm

- 1 tubo corrugato completo di impugnatura ergonomica
- 2 tubi rigidi di prolunga
- 1 spazzola multiuso per pavimenti e liquidi
- 1 bocchetta a lancia

#### SISTEMI FILTRANTI

- 1 cartuccia filtro aria superficiale 1900 cm<sup>2</sup> 12 micron nom.
- 1 filtro anti-schiuma PPI 45/PPI 30

**Funzione soffiante**

## 1874

018740050

### Aspiratore 50 litri per solidi e liquidi bidone in acciaio INOX

#### CARATTERISTICHE TECNICHE

- motore by-pass bistadio
- tensione 230/240 V
- frequenza 50/60 Hz
- potenza Max 1350 W
- portata d'aria l/sec. 55
- depressione Max 240 mbar
- capienza Max bidone 50 l in acciaio Inox
- emissioni acustiche <63 dB(A)
- lunghezza cavo 6 m
- carrello porta accessori

~~€ 625,00~~ € 360,00

#### ACCESSORI IN DOTAZIONE Ø 45mm

- 1 tubo corrugato completo di impugnatura ergonomica
- 2 tubi di prolunga in acciaio inox
- 1 telaio spazzola industriale
- 1 inserto industriale moquette
- 1 inserto industriale con gomme raccogli liquidi
- 1 bocchetta a lancia

#### SISTEMI FILTRANTI

- 1 sacco in carta filtro
- 1 cartuccia filtro superficiale 5200 cm<sup>2</sup> 12 micron nom.
- 1 filtro anti-schiuma PPI 45/PPI 30

**Ruote antitraccia**



50 l



## 7042LCD



Maschera LCD ad oscuramento automatico, per saldatura ad elettrodo, MIG/MAG, TIG e plasma. Alimentazione a celle solari e batterie al litio per una durata eccezionale del filtro LCD



070420001

~~€ 142,00~~ € 82,00

- Area di visuale 98x43 mm
- Tonalità di oscuramento DIN 9-13 con regolazione esterna
  - Protezione UV/IR
  - Tempo d'oscuramento 1/25000 s (ansi Z87.1)
- Tempo di rischiaramento 0.25-1s
  - Sensibilità e ritardo dell'oscuramento regolabili
- Accensione e spegnimento automatici
  - Funzione di smerigliatura
- Forma ottimizzata per agevolare la respirazione a schermo abbassato

## 1860K/160A

018600160

### Saldatrice inverter

ad elettrodo in corrente continua (DC), compatta e facile da trasportare fornita di cavi, martospazzola e tracolla. Funzioni: arc force, hotstart, anti-sticking, protezione termostatica



~~€ 798,00~~ € 450,00



200 mm  
330 mm  
130 mm

Corrente di regolazione	5÷155A
Alimentazione	1x230V
Potenza assorbita	MAX 3,7 KVA
Fattore di utilizzo (40°C) :	35% - 150 A 60% - 130 A 100% - 100 A
Fusibile ritardato	20 A
Protezione	IP21
Uso con generatori	✓
Temperatura di esercizio	-15/+40° C (+5/+104° F)
Elettrodi utilizzabili	Ø 1.5 - 4 mm utilici, basici, inox, ghisa, ecc.

## 1852R1750 Novità



018520175

### Riscaldatore ad induzione portatile

- Riscalda e sblocca bulloni, dadi, mozzi e cuscinetti particolarmente bloccati senza l'utilizzo di fiamme
- Permette di scaldare qualsiasi tipo di metallo ferromagnetico

~~€ 1.125,00~~ € 645,00

#### Dotazione:

- Due serpentine frontali con diametro 19 e 26 mm per sblocco dadi ①
- Una serpentina piatta per scaldare le superfici ③
- Una serpentina flessibile lunga 800 mm ②
- Valigetta di plastica

#### Dati tecnici:

- Tensione di ingresso: 230V AC, 50/60 Hz
- Corrente di ingresso: max. 7,5A
- Potenza: max. 1.75 kW

#### VANTAGGI

- 1 Risparmio di tempo: riscaldamento veloce e con grande precisione
- 2 Sicurezza anti incendio: non genera fiamme, massima sicurezza per l'operatore
- 3 Praticità: utilizzabile con una sola mano e serpentine facilmente intercambiabili

#### CAMPI DI APPLICAZIONE

- Automotive
- Manutenzione industriale
- Industria aeronautica
- Industria navale
- Industria petrolchimica



200x140x75 mm

**RAPIDO SBLOCCAGGIO  
DI DADI E BULLONI**

**MASSIMA SICUREZZA  
SENZA L'USO DI FIAMME**



## 1837N

Lampada magnetica snodata con LED ad alta luminosità fino a 400 Lumen

- Batterie (non incluse) :  
- 1xAA (durata 25/69 h)  
- 2xAA (durata 33/96 h)  
- 3xAA (durata 43/124 h)
- Lumen: 400>40>OFF
- Indicatore di carica
- Cono luminoso regolabile
- IPX6

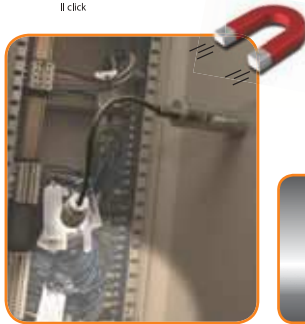
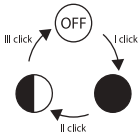

018370002

~~€ 62,00~~ € 36,00



Torcia LED ad alta luminosità in robusto alluminio anodizzato



finitura opaca



## 1834P XL

018340330

~~€ 71,00~~ € 41,00

## 1836A Novità

Lampada da testa a LED, con doppia luminosità e sensore ON/OFF contactless



- 120/65 lumen
- IP54
- pile: 3xAAA include



018360050

~~€ 39,00~~ € 23,00

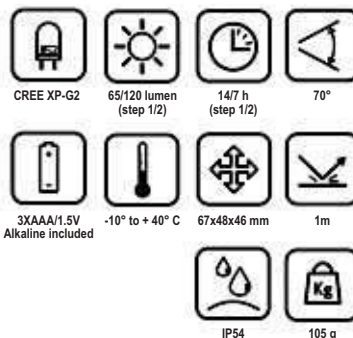

## 1834P L

018340325

~~€ 57,00~~ € 33,00



## 1834P M

018340320

~~€ 35,00~~ € 20,00



## 1834P S

018340310

~~€ 28,50~~ € 16,50





# 1837PLUS Novità



018370026

~~€ 215,00~~ € 126,00

## Faretto a LED da cantiere

- Luminosità: 3000 lumen; regolabile ( 10%; 25%; 50%; 75%; 100%)
- Alimentazione: 100-240V AC - 50/60Hz; 26W
- Protezione impatti: IK07
- Cavo: 5m / 3x1mm<sup>2</sup>
- Dimensioni: 235 x 83 x 233 mm



# 1838FLASH Brevettato



018380300

~~€ 245,00~~ € 141,00

Faretto ricaricabile ultracompatto, studiato per offrire la migliore soluzione possibile in ogni utilizzo.

- LED ad altissima luminosità
- IP 65
- Robusto ed affidabile
- Batteria ai polimeri di litio 7,4 V 4000 mAh

**Illuminazione  
abbondante  
e sempre pronta:**  
con una capacità illuminante  
massima di 720 Lumen e con  
la possibilità di lavorare  
a batteria o a cavo  
è sempre pronta all'uso



90°



**Compatto  
80x95x155 mm**

Posizionabile ovunque:  
su piani, con cavalletto  
1/4", con magneti  
svitabile







## 1838/11LED



018380111

Lampada ricaricabile con LED ad altissima luminosità batteria ai polimeri di litio

- Corpo compatto in gomma antiscivolo
- Con stazione di ricarica 110-230Vac/50-60Hz



~~€ 122,00~~ € 70,00

LED in testa per illuminazione multi direzionale

testa ancora più compatta

Gancio orientabile



<20%



Vetrino frontale facilmente sostituibile



## 1842LED/BM



018420301

Lampada con LED ad altissima luminosità, 100-240Vac

- Corpo compatto in gomma antiscivolo
- Vetrino frontale facilmente sostituibile
- Gancio orientabile
- Con LED in testa per illuminazione multidirezionale

~~€ 102,00~~ € 59,00



## 1842LED/ABM



018420311

Lampada con LED ad altissima luminosità, 12-24 V; AC-DC

- Corpo compatto in gomma antiscivolo
- Vetrino frontale facilmente sostituibile
- Gancio orientabile
- Con LED in testa per illuminazione multidirezionale

~~€ 95,00~~ € 55,00



## 1846LED/BM



018460301

Avvolgitore automatico completo di lampada a LED, 100-240 Vac

- Con trasformatore di sicurezza 230/24V Max. 60 W

~~€ 305,00~~ € 176,00



## 1846LED/ABM



018460311

Avvolgitore automatico completo di lampada a LED alimentazione 12-24 V; AC-DC Max. 25 W

~~€ 295,00~~ € 171,00



## 1760PA/AC-DC



017600000

~~€ 239,00~~ € 139,00

**Pinza amperometrica e multimetro digitale**

- permette le misurazioni di CC e CA fino a 1000 A
- funzione multimetro integrata  
A: AC/DC  
V: AC/DC



**PARAMETRI RILEVABILI**  
 Tensione DC: 0.1mV ÷ 600V  
 Tensione AC: 0.1mV ÷ 600V  
 Corrente DC: 0.01A ÷ 1000A  
 Corrente AC: 0.01A ÷ 1000A  
 Resistenza: 0.1Ω ÷ 40MΩ  
 Capacità: 0.001nF ÷ 40 μF  
 Frequenza: 0.001kHz ÷ 4kHz  
 Temperatura: -40°C ÷ 1000 °C  
 -40°F ÷ 1832°F  
 Alimentazione:  
 1 batteria da 9V (inclusa)

## 1497/C94

**Assortimento di 94 connettori per test su autovetture**  
 Utilizzabili con i principali strumenti di diagnosi

014970300

~~€ 300,00~~ € 173,00



**INCLUSI NELL'ASSORTIMENTO:**

- 2 rubacorrente
- 2 potenziometri
- 2 spie di segnalazione
- 2 connettori SRS
- 2 coccodrilli
- 2 sonde ad ago
- 2 puntali
- 2 connettori doppi a banana
- 4 connettori a banana singoli
- 24 terminali maschio piatti 0.6÷6 mm
- 12 terminali maschio tondi 1.6÷3.9 mm
- 24 terminali femmina piatti 0.6÷6 mm
- 12 terminali femmina tondi 1.6÷3.9 mm

430x390x100 mm

## 1497/C23

**Assortimento 23 utensili per sblocco connettori elettrici**

014970200

~~€ 170,00~~ € 99,00

430x310x50 mm







## 961D

009610500

### Videoscopio digitale elettronico con sonda da 5,5 mm

Permette di visualizzare, fotografare e registrare singole immagini e filmati direttamente sullo strumento

- sonda con testa Ø 5,5 mm e lunghezza 90 cm
- display LCD TFT da 7" (18 cm) con risoluzione da 800x480
- camera digitale con visione frontale e laterale
- zoom digitale 2X

**Sonda Ø 5,5 mm con camera frontale e laterale a 4 led**



~~€ 1.330,00~~ € 735,00

#### DATI TECNICI:

Distanza ottimale di visualizzazione	2,5-30 cm
Alimentazione	3,7V - 4200 mAh
Autonomia stimata	2,5-4 ore
Peso	520g
Risoluzione sensore	640x480 pixels (digitale)
Ampiezza di visualizzazione	60 gradi
Risoluzione di video e foto	640x480
Dimensioni	184x144x27 mm



Ingresso micro-SD Card



Microfono



Micro USB



Micro HDMI

## 961D/CF3,8

009610511

Sonda da 1 metro con camera frontale da 3,8 mm

~~€ 560,00~~ € 318,00



## 961D/DC8,5

009610513

Sonda da 1 metro con doppia camera UV

~~€ 485,00~~ € 278,00



## 1498/4A



014980104

- selezione automatica della tensione 6 o 12 Volt
- selezione automatica del tipo di batteria

~~€ 120,00~~ € 69,00



**Pb** Wet, Gel Dry, Agm **IP65**

#### DATI TECNICI:

Tensione di alimentazione	220V-240V
Frequenza	50-60 Hz
Corrente nominale (min-max)	1-4 Amp
Tensione della batteria	6V/12V
Capacità batteria	4Ah-80Ah
Tempo di ricarica	12 ore
Grado di protezione	IP65

#### Caricabatterie elettronico

- protezione di inversione di polarità, corto circuito
- display digitale retroilluminato
- gancio di fissaggio reclinabile

## 1498/8A



014980108

- funzione recupero batterie scariche
- funzione alimentatore 13,8V-5A

~~€ 169,00~~ € 98,00



**Pb** Wet, Gel Dry, Agm **IP65**

#### DATI TECNICI:

Tensione di alimentazione	220V-240V
Frequenza	50-60 Hz
Corrente nominale (min-max)	2-8 Amp
Tensione della batteria	12V
Capacità batteria	5Ah-160Ah
Funzione Memory Saver	13,8V - 5A
Grado di protezione	IP65





# 1498/40A



014980140

## Caricabatterie avviatore multifunzione 12-24V carrellato

- 3 cicli di carica programmati e 1 ciclo manuale
- potenziometro di regolazione elettronica
- processi specifici di carica WET-SPIRAL/GEL-AGM
- sistema di controllo e protezione elettronico
- processo di carica a 10 fasi
- funzione desolfatazione e recupero batteria
- funzione supply
- doppia tensione 12-24V
- idoneo anche per batterie Start&Stop
- pinze professionali in ottone isolate in gomma



IP65

~~€ 910,00~~ € 530,00



2 in 1  
caricabatterie  
+ avviatore

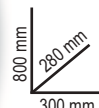

### DATI TECNICI:

Alimentazione	230V
Tensione in uscita	12-24V
Corrente di carica	1-40A
Corrente di avviamento	350A max cc
Capacità di ricarica	4-450Ah



# 1498TB/12



014980400

## Tester digitale per batteria 12V

- permette di effettuare i seguenti test: batteria, alternatore, avviamento e massa veicolo
- dotato di software per stampare il test eseguito da PC
- display retroilluminato
- struttura compatta e antiurto
- software in 10 lingue
- dotato di un apposito ingresso per il collegamento di una mini stampante estraibile (accessorio opzionale)

### DATI TECNICI:

- **applicazioni:** Test batterie 12V test alternatore 12V carica - Test sistemi avviamento
- **intervallo di funzionamento:** 100-1700 CCA
- **normative di riferimento:** CCA,SAE,DIN,EN,IEC,JIS
- **batterie supportate:** PB, Wet, Gel, Agm, Mf, Vrla, Sli
- **voltmetro:** 9V-15V
- **lunghezza cavi:** 180 cm
- **lingue:** Italiano, Inglese, Francese, Tedesco, Spagnolo, Polacco, Rumeno, Olandese, Svedese e Finlandese
- **accessori inclusi:** Cavo USB e software

~~€ 490,00~~ € 285,00



370x270x100 mm



# 1498ST/TB





014980410





## Mini stampante termica per Tester 1498TB/12

- possibilità di collegare la mini stampante direttamente sul tester
- permette di stampare i risultati del test effettuato

~~€ 186,00~~ € 108,00



**1498/12**  **12V**  014980480

     **€ 535,00 € 305,00**

### Avviatore per autovetture 12 V portatile

- corrente di spunto 2200 A
- batteria ermetica al piombo electrolyte solido (AGM)

Batteria



 **1498/24**  **12-24V**  014980490

     **€ 1.080,00 € 615,00**

### Avviatore per auto e veicoli commerciali 12-24 V portatile

- corrente di spunto 4200 A (12 V), 2100 A (24 V)
- batteria ermetica al piombo electrolyte solido (AGM)



 **1498LT/12** **Novità** 

### Avviatore portatile ultraleggero ad alte prestazioni

Il microprocessore permette la totale protezione contro:

- inversione di polarità
- corto circuito
- voltaggio errato
- sovraccarico
- sottoscarica
- sovraccarica

DATI TECNICI:	
Tensione di utilizzo	12 V
Amperaggio continuo	800 A
Amperaggio massimo di avviamento	2000 A
Amperaggio di picco	4000 A
Lunghezza cavi	580 mm
Tipo batteria	4 celle LifePo4
Funzione Salva memoria	SI
Dimensioni	300 x 225 x 72 mm
Dotato di alimentatore di ricarica 12 V 1,3A	



**€ 645,00 € 369,00**



Batteria di ultima generazione **LifePo4**

Solo 2,5 kg!

Include funzione salva memorie

 014980012

**1498MN/12** 

### Avviatore portatile multifunzione

#### FUNZIONI

- avviamento di veicoli con batteria 12 Volt (diesel e benzina fino a 2000 cc.)
- ricarica di tablet, telefoni cellulari e apparecchi elettronici in genere
- torcia LED multifunzione electrolyte solido (AGM)

DATI TECNICI:	
Corrente di spunto	600A
Tipo di batteria	LiCoO2
Uscita per avviamento	12 Volt
Peso	1 Kg



uscita USB per caricare dispositivi elettronici

**€ 268,00 € 154,00**



 014980000

 240x185x60 mm





# 1464T

014640050

## Tester digitale per la misurazione di pressione e compressione

Con kit 960AD/TP2 e 1464IC permette di verificare:

- compressione motori benzina e diesel
- pressione olio motore
- bassa pressione common rail
- pressione iniezione benzina

Con kit 1464AP permette di verificare:

- pressione reale circuito common rail
- pressione pompa alta pressione

### CARATTERISTICHE

- display touch screen da 5"
- batteria ai polimeri di lito ricaricabile
- completo di sensore da 80 bar (basse pressioni) e cavo USB



~~€ 680,00~~ € 390,00

# 960AD/TP2

009600510

## Set di adattatori per 1464T e 960TP

- finti iniettori
- finte candele
- adattatori candela
- adattatori tappi olio
- raccordi iniezione benzina
- set guarnizioni di ricambio



~~€ 398,00~~ € 229,00

430x310x50 mm

# 1464AP

014640450

## Set per la verifica dell'impianto alta pressione dei motori diesel common rail, con 1464T

- set tubi alta pressione
- raccordi di collegamento
- sensore da 2.000 bar

~~€ 605,00~~ € 348,00

430x310x50 mm



# 1464IC

014640350

## Set di finti iniettori e finte candele per 1464T

Permette di collegarsi al motore per la verifica della compressione nei motori diesel con tester digitale 1464T.

~~€ 445,00~~ € 258,00

- n° 22 false candele
- n° 5 falsi iniettori
- n° 1 kit falso iniettore universale per truck, motori marini e macchine agricole



559x312x50 mm



**960KPC** **1/4"**

009600780

**Estrattore reversibile ad impulsi con coppia regolabile per candele di preriscaldamento**

- l'estrattore pneumatico a coppia regolabile e le bussole speciali consentono di svitare le candele bloccate riducendo al minimo il rischio di danneggiamento
- 5 bussole da 1/4" macchina lunghe, speciali per candele: 8-9-10-11-12 mm, 2 prolunghe e 1 snodo
- 4 coppie di serraggio regolabili: 10-20-30-40 Nm
- regolazione destrorsa e sinistrorsa

~~€ 247,50~~ **€ 145,00**

420x185x60 mm

**Evita la rottura delle candele durante lo smontaggio****960KC/M....**

009600801

**Assortimento di utensili per la rimozione delle candele di preriscaldamento spezzate o danneggiate**

380x290x50 mm

~~€ 310,00~~ **€ 179,00****Per candele con filetto M8-M9-M10****960EPC**

009600790

**Set di utensili per l'estrazione dell'elettrodo delle candele di preriscaldamento**

- permette una corretta e rapida estrazione della parte terminale dell'elettrodo in caso di rottura o grippaggio all'interno della sede della candela.
- adatto per candele con filettatura: M8x1 - M9x1 - M10x1 - M10x1,25

~~€ 485,00~~ **€ 282,00**

270x230x80 mm



ZONA DI ROTTURA

# 1462KI

014620235

**Assortimento di utensili per estrazione iniettori Diesel Common Rail**  
**Permette la rimozione degli iniettori DELPHI-BOSCH-SIEMENS-DENSO**

- funzionamento meccanico e idraulico
- include un martinetto idraulico da 12 tonnellate
- può essere utilizzato direttamente sul veicolo con motore montato
- le numerose possibilità di regolazione sulla testata permettono di lavorare sulla maggior parte dei motori in circolazione



590x470x140 mm



~~€ 1.990,00~~ € 1.150,00

# 1462/KU **Novità**

014620100

**Assortimento utensili universale per estrazione iniettori Diesel Common Rail**  
**Completo di pinza e massa battente**

- Consente di eseguire l'estrazione degli iniettori con due procedure:
- utilizzando la pinza con bracci di presa che si adattano perfettamente alla forma dell'iniettore
  - utilizzando l'adattatore a snodo e il perno che andrà avvitato al raccordo del condotto Common Rail, l'intervento potrà essere eseguito senza procedere allo smontaggio della testa dell'iniettore
- Iniettori: Bosch, Denso, Siemens

**Iniettori Bosch, Denso e Siemens**



390x290x100 mm



~~€ 570,00~~ € 330,00

# 1462AD/BSC **Novità**

014620435

**Adattatore per estrazione iniettori Bosch Common Rail**  
**Da utilizzare con articoli Beta 960KI, 1462KI e 1462/KU**

- estrattore speciale che consente la rimozione di iniettori Bosch con esagono 29 e 30 mm
- l'attrezzo garantisce l'estrazione senza rimuovere la connessione elettrica in plastica
- evita apertura/smontaggio dell'iniettore che rimane intatto e integro dopo la rimozione



~~€ 165,00~~ € 98,00



**960PI/S Novità**

1/4

009600214

**Kit per pulizia sedi iniettori**

Incluso nel kit:

- 3 spazzole in acciaio Ø 18, 22, 25 mm per pulizia sedi iniettori
- 2 spazzole Ø 14 e 16 mm per pulizia fondo sedi iniettori
- 6 tappi per occlusione foro collegamento camera di combustione
- 1 scovolino per pulizia foro collegamento camera di combustione
- 1 portainseri flessibile con impugnatura

360x140x50 mm

~~€ 117,00~~ € 69,00**Impugnatura porta-accessori flessibile per tutte le angolazioni****1462/KMRC Novità**

014620070

**Assortimento utensili per estrazione iniettori su motori Mercedes 2.1L, 2.2L, 3.0 V6 e Chrysler**

Per iniettori Bosch (2.1 e 2.2L) e Delphi (3.0). Si può procedere alla rimozione degli iniettori senza rimuovere il motore.

Particolarmente indicato per i modelli: Mercedes Vito, Vario, CLK, Sprinter, Viano, Classe M, GL, C, GLK, E, CLS, S, R, G Chrysler 300 C

~~€ 548,00~~ € 320,00**MOTORI MERCEDES E CHRYSLER****INIETTORI BOSCH E DELPHI**

310x300x118 mm

**1462AD/SMN Novità**

014620436

**Kit di adattatori per estrazione iniettori Siemens e Denso**

- Da utilizzare con articolo Beta 960KI/1462KI
- per lo smontaggio e il successivo ancoraggio degli iniettori Siemens e Denso
- il doppio ancoraggio dell'iniettore sia nella parte interna che esterna, garantisce la massima tenuta durante l'operazione di estrazione

SIEMENS DENSO

~~€ 248,00~~ € 145,00

240x205x48 mm





# 1477/C10



014770310

~~€ 125,00~~ € 72,00

**Assortimento di 9 inserti e 1 chiave curva per dadi tendicinghia in cassetta di plastica**

- 1 chiave curva con attacco per inserti
- 4 inserti poligonali doppi:
  - 12x14 - 13x15 - 16x17 - 18x19 mm
- 5 inserti per viti con profilo Torx:
  - ⊗ E10 - E12 - E14 - E16 - E18



530x110x55 mm

# 1474E/VW Novità

014740120

**Estrattore ad espansione per bobine accensione gruppo Volkswagen**

~~€ 20,00~~ € 11,50



∅  
mm  
4,85 ÷ 5,95



# 1529PI Novità

015290051

**Estrattore universale per puleggia pompa iniezione**

~~€ 82,00~~ € 48,00

- permette un rapido e preciso smontaggio della puleggia pompa iniezione carburante.
- particolarmente indicato per Fiat, Ford, Volkswagen, Citroen e Peugeot



Include 3 coppie di viti per serrare l'estrattore alla puleggia:  
M6 x 1.0 x 49 mm  
M7 x 1.0 x 75 mm  
M8 x 1.25 x 76 mm

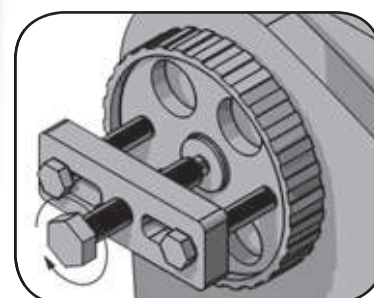

**1759HD/3****Strumenti per controllo tenuta impianto di raffreddamento e riempimento circuito**

Permette di verificare sotto pressione le perdite del circuito (tubi, giunti, pompe, radiatori) e riempire velocemente il circuito evitando la formazione di bolle d'aria.

 017590063

~~€ 444,00~~ € 259,00

 600x500x140 mm
**1480**
 014800010

~~€ 295,00~~ € 173,00

**Kit riempimento filtri gasolio per auto senza pompa elettrica**

Utilizzabile anche con pistola gonfiagomme

Il kit include:

- attacchi rapidi GM
- attacchi rapidi Renault, GM, Fiat Ø interno 6 mm
- attacchi rapidi Renault, GM, Fiat Ø interno 7 mm
- attacchi rapidi Ford
- attacchi rapidi PSA Ø interno 6 mm
- attacchi rapidi PSA Ø interno 7 mm
- attacchi rapidi Ford
- 2 adattatori conici per vetture senza attacchi rapidi

 410x320x70 mm
**1482C Novità**
 014820022

**2 coppie di cunei per sgancio raccordi filtri gasolio gruppo Fiat, Volkswagen, Jeep, Chrysler e Volvo**  
Rapida sostituzione del filtro senza danneggiare irrimediabilmente i raccordi

~~€ 49,00~~ € 29,00



**NON DANNEGGIA I RACCORDI**  
**SOSTITUZIONE FILTRO RAPIDA E VELOCE**



# 1482

014820001

Chiave regolabile autoserrante per ghiera galleggianti serbatoio



Ø mm 89÷170

~~€ 85,00~~ € 50,00



## 1482A/1 **Novità** □ 12"

014820005

Chiave a 3 zampe per ghiera galleggianti serbatoio con ghiera in alluminio

Per agire sulla ghiera in alluminio montata dal 2011 su vetture dei gruppi Fiat, Volkswagen, Opel, Chevrolet, Mercedes e BMW



Ø 185 mm

~~€ 59,50~~ € 34,80

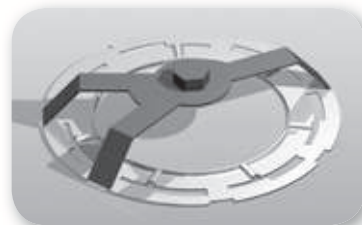

## 1482A/2 **Novità** □ 12"

014820006

Chiave per ghiera galleggianti serbatoio a 12 settori

Per agire sulla ghiera senza intagli laterali montata su vetture e furgoni del gruppo Fiat e Ford

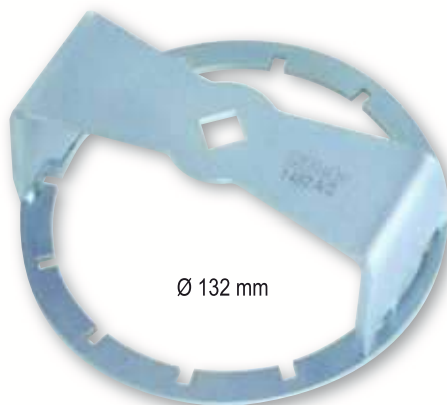

Ø 132 mm

~~€ 54,50~~ € 32,00

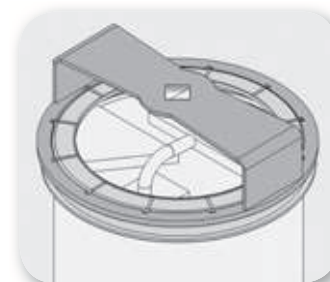

## 1482A/3 **Novità** □ 22 mm

014820007

Chiave per ghiera galleggianti serbatoio gruppo PSA

Il disegno permette di operare sull'asse decentrato rimuovendo la ghiera, senza danneggiare il delicato pescante



Ø 151 mm

~~€ 69,00~~ € 40,00

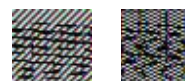
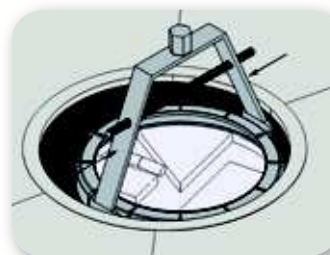

- indicatore di livello
- coppa di grande diametro con griglia scolafiltro capacità 12l
- svuotamento pneumatico del serbatoio con tubo da 1,8 m
- vaschetta portautensili

**1877** 

 018770008

~~€ 560,00~~ **€ 320,00**

Recuperatore olio esausto  
carrellato con serbatoio  
da 90 litri



**1877A** 

 018770080

~~€ 998,00~~ **€ 573,00**

Recuperatore/aspiratore  
olio esausto, carrellato  
con serbatoio da 90 litri  
e precamera

- precamera trasparente  
capacità 9,5l
- tubo aspirazione da 1,8 m



In dotazione:

- 1 sonda rigida Ø 5x700 mm
- 1 sonda flessibile Ø 5x700 mm
- 1 sonda rigida Ø 6x600 mm
- 1 sonda flessibile Ø 6x700 mm
- 1 sonda flessibile Ø 7x700 mm
- 1 sonda flessibile Ø 8x700 mm
- adattatori per VW, BMW, CITROËN, MERCEDES

**1494VW** **Novità**

 014940305

Chiave speciale  
per tappi olio in plastica  
motori gruppo Volkswagen  
Permette di rimuovere e installare  
il tappo in plastica dalla coppa dell'olio.  
Specifico per vetture del gruppo  
Volkswagen con motori TFSI e TDI

 10 mm

~~€ 17,50~~ **€ 10,30**







## 1494M **Novità**

014940401

**Attrezzo per tappi olio esagonali magnetico e flessibile**

Permette di svitare il tappo senza rischi di scottature e senza sporcarsi

L	F	Ø
mm	kg	mm
293	2,5	19

~~€ 17,50~~ € 10,30



### LAVORO SICURO E PULITO

## 1758LG **Novità**

**Lamina modellabile in alluminio rivestita in gomma, per la canalizzazione dei liquidi**

017580006

L	H
mm	mm
365	168

~~€ 34,00~~ € 19,90



### NUMEROSE POSSIBILITÀ DI UTILIZZO

### FLESSIBILE E ADATTABILE

## **Novità**

**Recipienti per liquidi pratico beccuccio flessibile removibile**



3l  
**1758R/3**

017580203

~~€ 13,50~~ € 7,80

5l  
**1758R/5**

017580205

~~€ 16,50~~ € 9,60

## 1878 3 **Novità**

**Vaschetta per recupero olio mozzi truck scarico dell'olio con salvagocia**



### PER OPERAZIONI RAPIDE E PULITE

018780003

~~€ 15,50~~ € 8,90

**1884**

018840010

**Attrezzo per l'inserimento di olio nei cambi manuali, automatici e nei differenziali**

Completo di 12 adattatori per la connessione diretta

- dotato di valvola di non-ritorno per un'efficace azione di inserimento dell'olio senza perdite
- portata: 70 cc a pompata
- capacità serbatoio: 7,5 litri
- massima viscosità olio utilizzabile: SAE 140

~~€ 372,00~~ € 215,00

## 12 ADATTATORI

FORD	AT-101
UNIVERSAL (Bmw, Honda, Nissan...)	AT-102
VW-AUDI	AT-103
VW-AUDI-PORSCHE	AT-104
VW-AUDI-MINI COOPER	AT-105
MERCEDES	AT-106
DSG	AT-107
VW-AUDI CVT	AT-108
VOLVO	AT-109
TOYOTA-LEXUS	AT-110
SKODA	AT-111
VW Passat/Tiguan <2007	AT-112

**1569/A**

015690011

**Assortimento di utensili per l'estrazione e l'introduzione dei silent block ponte posteriore, paraoli albero motore e cuscinetti ruota**

- le boccole possono essere utilizzate sia direttamente sul veicolo che alla pressa idraulica
- estrazione diretta con chiave
- facilità di utilizzo, non servono macchine pneumatiche o idrauliche
- il kit comprende:
  - 4 barre filettate: M10-M12-M14-M16
  - 4 rondelle
  - boccole per diametri da 44 a 82 mm

~~€ 795,00~~ € 460,00

530x415x115 mm

**Novità**

Inseritori a percussione per cuscinetti conici e paraoli

**1569CP/50**

015690750

~~€ 100,00~~ € 58,50

A min ÷ Max 9,5 ÷ 50 mm L 130 mm

**1569CP/90**

015690790

~~€ 126,00~~ € 73,50

A min ÷ Max 18 ÷ 90 mm L 145 mm



## 1530/C5

### Kit per estrazione mozzi e cuscinetti ruote a 3,4,5 fori

Il kit comprende:

- 1 flangia universale 96+138 mm
- 1 vite idraulica da 12 tonnellate
- 1 massa battente da 2,8 kg indispensabile per mozzetti senza bullone di fissaggio centrale



760x320x120 mm

015300300

~~€ 420,00~~ € 245,00



## 437K/8 Novità

32 mm

### Assortimento per ripristino filetti semiassi

Permette di ripassare e ravvivare il filetto originale

Incluse nel kit:

- misure metriche: 20x1,25 - 20x1,5  
22x1,00 - 22x1,5  
24x1,5 - 24x2,00
- misure in pollici: 3/4x20 - 13/16x20

200x110x30 mm



004370020

~~€ 60,00~~ € 35,50

**RAPIDO  
ED EFFICACE**

**UTILIZZABILE  
SENZA SMONTARE  
IL SEMIASSE**

## 985/B7 Novità

### Assortimento di 7 perni guida per montaggio ruote

Misure incluse:

- M12x1,25 maschio
- M12x1,25 femmina
- M12x1,5 maschio
- M12x1,5 femmina
- M14x1,25 maschio
- M14x1,5 maschio
- M16x1,5 maschio



009850007

~~€ 76,00~~ € 44,50

**DIMINUISCE LA FATICA  
DELL'OPERATORE**



**MONTAGGIO  
RAPIDO E PRECISO**

## 1566P Novità

### Pinza per anelli elastici millerighe semiassi

La pinza comprime l'anello elastico semplificando l'inserimento del semiassetto nel giunto omocinetico

**PRATICO  
E VELOCE**

~~€ 50,00~~ € 29,00

015660091



L	A Max
mm	mm
280	36





**1471M/C22**

014710101

Utensile pneumatico per arretrare e ruotare i pistoncini dei freni a disco destrorsi e sinistrorsi con accessori

- martinetto automatico
- 150 kg di spinta
- pressione di utilizzo 5+8 bar



~~€ 236,00~~ € 135,00



350x310x85 mm

**971TSP**

009710025

Strumento per sensori di pressione dei pneumatici

lettura delle informazioni dai sensori TPMS quali:

- ID del sensore
- pressione di gonfiaggio
- temperatura
- stato batteria
- attivazione dei sensori
- programmazione sensori universali



~~€ 990,00~~ € 545,00

Lo strumento dispone di una banca dati che supporta le operazioni di riparazione come:

- coppie di serraggio
- codici di ricambio originali e di sensori universali compatibili

**DATI TECNICI:**

Processore	Cortex M0+, 48 MHz
Display	1,5" LCD retroilluminato
Risoluzione	64x128 pixels
Comunicazione via cavo	USB
Comunicazione Wireless	Bluetooth classe 2 con antenna integrata
Batteria	Tipo Li-ion, Capacità 1100 mAh, Tensione 3,7V
Autonomia	circa 8 ore
Ricarica	via USB, circa 3 ore
Aggiornamenti	è previsto un servizio di aggiornamento periodico della banca dati veicoli dopo il primo anno



**INCLUDE OLTRE  
50 MARCHE  
DI VEICOLI**

**1° ANNO DI  
AGGIORNAMENTI  
INCLUSO**

**1483/K12** **Novità**

014830012

Kit per smontaggio valvole impianto aria condizionata con serie di inserti pentalobati

Inclusi nel kit:

- 2 bussole femmina ottagonali Ø 12 e 15 mm per valvole alta pressione
- 2 bussole maschio a forchetta sezione 2,2 e 3,2 mm per valvole a farfalla
- 1 serie di inserti pentalobati misura: PT10, PT15, PT20, PT25, PT27, PT30, PT40



~~€ 30,00~~ € 17,50



120x80x35 mm

**INSERTI PENTALOBATI**

## 960/22EP **Novità**



009600052

**Chiave snodata a doppia impronta per sonde Lambda**  
 Grande versatilità d'uso grazie alla doppia impronta esagonale/poligonale e allo snodo a 180°

~~€ 40,00~~ € 23,50

L	○	○
mm	mm	mm
300	22	22



## 1476GT **Novità**

014760050

**Pinza per rimozione supporti in gomma per tubi di scarico**

~~€ 26,00~~ € 15,00

A Max	L	$\frac{S}{2}$
mm	mm	mm
58	280	3



## 1476PSA **Novità**

014760060

**Pinza per fascette di scarico con perno, gruppo PSA**  
 La forma dei becchi e il blocco automatico della cremagliera permettono di operare senza sfilare il perno

~~€ 31,00~~ € 18,00

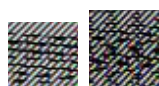

A Max	L	S
mm	mm	mm
60	309	12,2



## 1478T **Novità**

014780101

**Pinza con testa orientabile per pioli in plastica con clips a pressione**  
 Testa orientabile a 90°

~~€ 34,00~~ € 20,00

L	S
mm	mm
240	4,5





1368



013680001

**Kit ripara plastiche**

- alimentazione 220+240 V con presa Shuko
- lunghezza cavo pistola termica 3,5 m
- lunghezza cavo alimentazione 1,35 m
- 2 regolazioni di potenza 35-75 W
- pistola termica con terminali in ottone a 2 angolazioni di inserimento graffetta: 0°-90°
- protezione input: disgiuntore termico
- protezione output: fusibile 10 A
- tasca metallica per riporre la pistola
- fornito senza graffette

~~€ 320,00~~ € 186,00

**PERMETTE DI  
RIPARARE  
VELOCEMENTE  
CREPE E ROTTURE  
DI PARTI IN PLASTICA**

**1368G/K400****Assortimento di 400 graffette per 1368**

In dotazione:

- 100 graffette a serpentina piccola
- 100 graffette a serpentina grande
- 100 graffette per angoli concavi
- 100 graffette per angoli convessi

013680140

~~€ 52,00~~ € 30,50**1567**

015670001

**Leva per estrazione testine braccio oscillante e ammortizzatori dal montante**

Un solo operatore riesce senza sforzo a posizionare la leva e a procedere al disassemblaggio

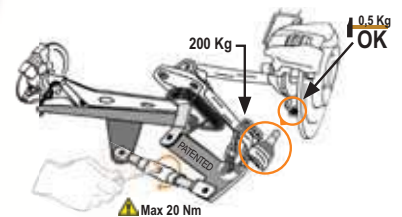
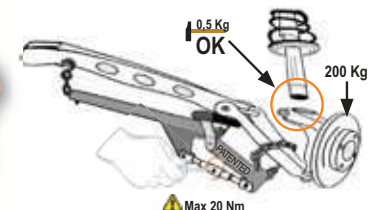
~~€ 250,00~~ € 146,00**1766ER Novità**

017660501

**Estrattore per raschiavetri con impugnatura**

permette di rimuovere agevolmente i raschiavetri senza rischi di danneggiamenti

~~€ 16,00~~ € 9,50



## 1550U



01550010

~~€ 2.280,00~~ € 1.290,00

**Smonta ammortizzatori pneumatico per autoveicoli, SUV e veicoli commerciali**

**MAGGIOR POTENZA:**

spinta massima 2 t (10 bar)

**POSIZIONE DI LAVORO:**

altezza di lavoro sulla staffa inferiore alzata fino a 875 mm

**DATI TECNICI**

Potenza spinta:

2 t (10 bar) - 1,6 t (8 bar) - 1,2 t (6 bar)

Corsa di compressione molla: 335 mm

**SPINTA MASSIMA 2 t**



• **SISTEMA UNIVERSALE DI PRESA SUPERIORE:**

consente con un'unica piastra adattabile superiore di comprimere tutti i diametri di molla sia destrorse che sinistrorse

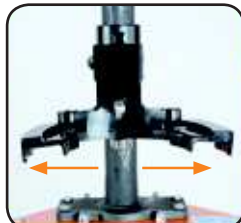

• **SISTEMA DI SICUREZZA ATTIVA SULLA MOLLA:**

attraverso il gancio di sicurezza e le 3 valvole di blocco è garantito il corretto posizionamento/alloggiamento della molla mantenendo tale posizione per tutta l'operazione di compressione. In caso di posizionamento "non conforme" della molla il sistema ferma la macchina.



• **AZIONAMENTO CON LEVA DI COMANDO:** maggior precisione e sensibilità durante la fase di compressione



• **GRIGLIA DI PROTEZIONE "FULL BODY":**

garantisce la massima sicurezza e copertura della zona di lavoro



• Fornito con 2 staffe inferiori per diametri 78-205 mm

**1550U/SS187**

015500018

~~€ 290,00~~ € 170,00

**Staffa sinistrorsa per 1550U**

particolarmente indicata per molle con profilo sinistro tipo Nissan Qashqai e Renault Koleos  
Diametro 105-187 mm



**1550U/M**

015500021

~~€ 275,00~~ € 160,00

**Morsa per smonta ammortizzatori 1550U**

permette il bloccaggio dello stelo dell'ammortizzatore



**1365/K13** **Novità**

013650013

**Pompa oleodinamica 10 t  
e kit accessori per carrozzeria  
in pratica valigia trolley**

~~€ 515,00~~ **€ 295,00**

Inclusi nel kit:

- pompa oleodinamica 10 tonnellate con tubo flessibile da 1,5 m attacco 1/2"
- pistone
- pinza divarica parafanghi capacità 500 kg
- piastra di appoggio 150x90 mm
- base a "L" 50x50 mm
- punzone a 4 punti
- punzone zigrinato tondo Ø 50 mm
- punzone a cuneo 43 mm
- prolunga 240 mm
- prolunga 450 mm
- prolunga 475 mm
- testa in gomma
- raccordo maschio maschio per montaggio accessori

≡ 900x420x180 mm

**1365P10** **Novità**

**Pompa oleodinamica**  
Tubo da 1,5 m attacco 1/2"

**Max 690 bar**

013650110

~~€ 225,00~~ **€ 130,00**

**3009**

030090001

**Carrello per  
movimentazione veicoli**

- Portata massima: 550 kg
- 4 rulli basculanti
- larghezza rulli 200 mm
- per ruote fino a 240 mm di larghezza

~~€ 330,00~~ **€ 192,00**



**IDEALE PER:**

- **RECUPERO VETTURE INCIDENTATE SU CARRO ATTREZZI**
- **AUTOFFICINE E CARROZZERIE**
- **MOVIMENTAZIONE AUTO ALL'INTERNO DI SHOW ROOM**

**RUOTE IN  
VULKOLLAN  
CON CUSCINETTO**

## 3002

030020001

### Letto sottomacchina e seggiolino

- struttura in acciaio
- rivestimento in PVC con imbottitura
- possibilità di regolare la posizione rapidamente: letto o seggiolino



~~€ 85,00~~ € 49,00

## 3003

030030001

### Letto sottomacchina in plastica antiurto



~~€ 65,00~~ € 37,50

## 3030/2T

030300020

### Sollevatore idraulico ribassato 2 t a 6 ruote

- ottima manovrabilità del sollevatore su pavimentazioni sconnesse e irregolari
- altezza minima piattello: 85 mm
- altezza massima piattello: 520 mm
- lunghezza: 860 mm
- larghezza: 400 mm
- portata massima: 2 tonnellate

~~€ 610,00~~ € 345,00

**STABILE E  
MANEGGEVOLE**



Il pedale permette un rapido avvicinamento



Doppie ruote anteriori basculanti in materiale plastico (PTFE) con cuscinetti





## 3065/40-20T

030650200

### Sollevatore oleopneumatico 40-20 tonnellate

- indicato per utilizzo su mezzi pesanti
- pratico e maneggevole per trasporto anche su officine mobili
- rientro automatico dei pistoni
- due valvole di discesa con controllo velocità sotto carico

#### Dati tecnici:

- portata: 40/20 tonnellate
- peso: 39 kg
- pressione di alimentazione: 8-10 bar
- consumo d'aria: 400 l/min

~~€ 2.350,00~~ € 1.340,00

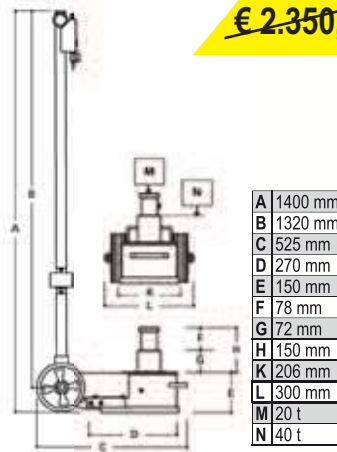

200 mm

## 3067/70-13T

030670130

### Sollevatore oleopneumatico 70-43-23-13 t

Versione lunga, adatta all'utilizzo su autocarri, autoarticolati, autobus e macchine agricole

- rientro automatico dei pistoni
- due valvole di discesa con controllo velocità sotto carico

#### Dati tecnici:

- portata: 70-43-23-13 tonnellate
- peso: 74 kg
- pressione di alimentazione: 8-10 bar
- consumo d'aria: 600 l/min

~~€ 4.380,00~~ € 2.500,00

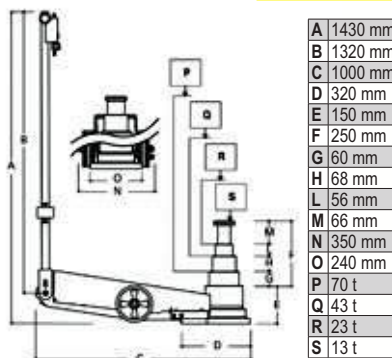

200 mm

# 3027 20

## Pressa idraulica con pistone mobile

- pompa manuale a 2 velocità
- pistone mobile
- stelo cromato
- ritorno automatico del pistone
- sicurezza idraulica in caso di sovraccarico
- manometro
- serie prismi a V inclusi

**CAPACITÀ MASSIMA: 20 t**

140 kg 030270020

~~€ 1.825,00~~ € 1.048,00

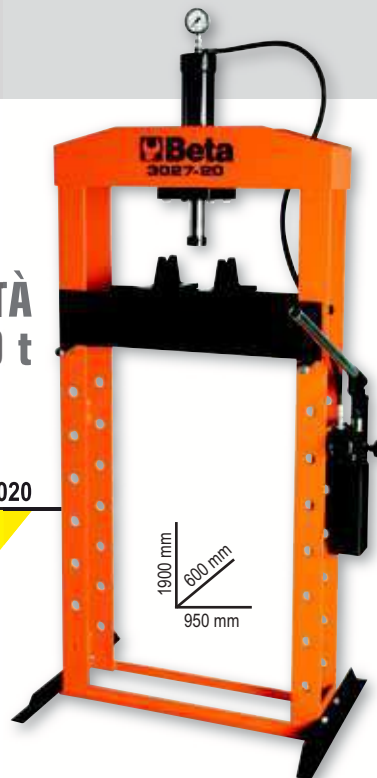

## PISTONE MOBILE E MANOMETRO INCLUSI



## Pressa idraulica con pistone mobile e argano

- pompa manuale a 2 velocità
- pistone mobile
- stelo cromato
- ritorno automatico del pistone
- manometro
- serie prismi a V inclusi

# 3027 30 **Novità**

030270030

~~€ 3.180,00~~ € 1.830,00

230 kg **CAPACITÀ MASSIMA: 30 t**

# 3027 50

030270050

~~€ 4.350,00~~ € 2.515,00

350 kg **CAPACITÀ MASSIMA: 50 t**

Comando a pedale per pressa idraulica 3027 20-30-50



**3027/KPP50** 030270555

~~€ 190,00~~ € 110,00

## 3027/KP

Serie di cacciaspine e piastra per pressa  
 ø cacciaspine: 5-10-14-18-24-29 mm



	Pressa		€
<b>3027/KP20</b>	3027 20	030270520	<del>€ 390,00</del> € 225,00
<b>3027/KP30</b>	3027 30	030270530	<del>€ 390,00</del> € 225,00
<b>3027/KP50</b>	3027 50	030270550	<del>€ 460,00</del> € 268,00

## Sollevatori idraulici da fossa e sottoponte

- pompa a pedale
- stelo cromato
- ruote in nylon

### 3026 0,3

030260003

~~€ 550,00~~ € 315,00 **300 kg**

- altezza minima: 1120 mm
- altezza massima: 1970 mm

### 3026 0,5

030260005

~~€ 650,00~~ € 375,00 **500 kg**

- valvola limitatrice di carico
- altezza minima: 1140 mm
- altezza massima: 1990 mm

**Novità**

030260010

~~€ 795,00~~ € 455,00 **1000 kg**

- valvola limitatrice di carico
- altezza minima: 1140 mm
- altezza massima: 1990 mm



## 3026/SP

### Supporto universale per trasmissioni

Permette ad un solo operatore di smontare e rimontare le trasmissioni di autovetture, veicoli commerciali e fuoristrada con rapidità e sicurezza.

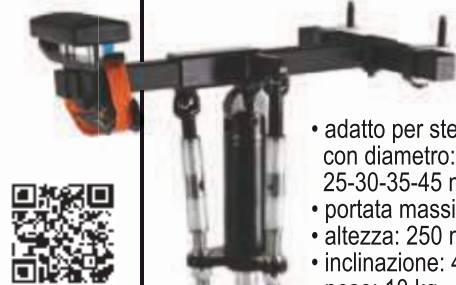

- adatto per steli con diametro: 25-30-35-45 mm
- portata massima: 150 kg
- altezza: 250 mm
- inclinazione: 45°
- peso: 10 kg

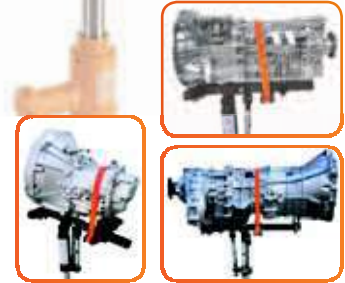

030260505

~~€ 540,00~~ € 310,00

## 3025

4 posizioni di carico:  
450-650-800-1000 kg

### Gru idraulica pieghevole con pompa a doppio effetto

- portata massima: 1 t
- la struttura richiudibile riduce al minimo gli ingombri
- con valvola limitatrice di carico e stelo cromato
- velocità di discesa controllata
- ruote in nylon
- altezza massima: 2400 mm



110 kg

030250001

~~€ 1.495,00~~ € 865,00

1650 mm  
550 mm  
1560 mm

## 3025/PF

030250011

~~€ 240,00~~ € 138,00

Pinza movimentazione fusti



**PORTATA MASSIMA 300 kg**

550 ÷ 640 mm



## 1366/K5 **Novità**

013660010

**Tirabolli pneumatico a massa battente da 1,1 kg**

Inclusi nel kit:

- 1 ventosa Ø 75 mm
- 1 ventosa Ø 100 mm
- 1 ventosa Ø 125 mm
- 1 gancio



**VENTOSE  
A FORTE TENUTA**



610x240x90 mm

~~€ 175,00~~ **€ 99,00**

## 1498PC **Novità**

014980801

**Stabilizzatore di tensione 12-24 V**

Indispensabile per proteggere le centraline in fase di saldatura ed avviamenti con avviatori

**12-24 V**



~~€ 75,00~~ **€ 43,50**



## 720LC/C3 **Novità** **12"**

**3 chiavi a bussola Macchina con inserti polimerici per dadi ruote**

in valigetta di plastica

- Misure: 17 - 19 - 21 mm



148x132x44 mm

007200653

~~€ 29,00~~ **€ 16,80**

## 720LCL/C3 **Novità** **12"**

**3 chiavi a bussola Macchina lunghe colorate con inserti polimerici per dadi ruote**

in valigetta di plastica

- Misure: 17 - 19 - 21 mm



210x50x150 mm

007200753

~~€ 62,00~~ **€ 36,00**

**720TC/S5** **Novità** **1 1/2"**

007200779

**Serie di 5 barre di torsione Macchina colorate per dadi ruote, in kit**

- Possibilità di utilizzare diverse misure di chiavi a bussola Macchina colorate con quadro da 1/2"
- Valori di coppia massima:  
90 Nm  
100 Nm  
110 Nm  
120 Nm  
135 Nm

260x50x175 mm

~~€ 82,50~~ € 48,00

**SET COMPLETO  
PER OGNI  
SERRAGGIO**

**720S/C6** **Novità** **1 1/2"**

007200907

**6 chiavi a bussola Macchina compatte con attacco quadro femmina 1/2", in cassetta di lamiera**

720S ○ 13-17-18-19-22-24 mm

195x80x55 mm

~~€ 51,00~~ € 29,50**720MRC** **1 1/2"**

007200631

**Chiave a bussola Macchina con inserto polimerico per vite ruota con profilo Mercedes Ø 17mm**



**Adatta per i modelli Mercedes:**

- Classe C e GLK (W204)
- Classe E (W211, W212, W207)
- Classe SLK (W172)
- Classe ML (W164, W166)
- Classe CL (W216)
- Classe S (W221, W222)

~~€ 15,00~~ € 8,80**1927SP-AM** **Novità**

019270000

**Supporto magnetico per avvitatore pneumatico**

- Dotato di due magneti ad alta tenuta con gomma protettiva
- Permette di alloggiare 1 avvitatore da 1/2", 4 bussole e 1 chiave dinamometrica
- Portata: 10 kg

~~€ 42,00~~ € 24,50

**MAGNETI RICOPERTI  
PER NON DANNEGGIARE  
LE SUPERFICI**



# 1927XM/K5



019270129

~~€ 273,00~~ € 157,00

**Assortimento di un avvitatore reversibile compatto e 5 bussole Macchina, in valigetta di plastica**

- Meccanismo impulsivo singolo martello
- Incredibilmente compatto e potente
- Comando d'inversione a pulsante azionabile con una sola mano
- Tre differenti livelli di potenza in avvitamento
- Scarico dell'aria attraverso l'impugnatura
- Gancio per bilanciatore



307x206x86 mm  
720 17-19-21-22-24 mm



1,3 kg

**SUPER COMPATTO E POTENTE 770 NM**

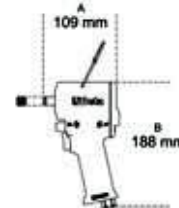

Velocità libera	giri/min	10.000
Massa battente		Singolo martello
Coppia massima	Nm	770
Capacità vite/dado	Cl 8.8	M22●34 mm
Capacità vite/dado	Cl 12.9	M18●27 mm
Attacco aria	GAS	1/4"
Pressione di utilizzo	Bar	6,2
Ø tubo consigliato	mm	10
Consumo aria medio	l/min	122

# 1927CD/K3 Novità



019270107

~~€ 385,00~~ € 198,00

**Assortimento di un avvitatore reversibile e 3 bussole Macchina, in valigetta di plastica**

- Meccanismo impulsivo doppio martello
- Leggero e bilanciato per un facile utilizzo
- Dotato di un'elevata coppia
- Comando d'inversione a leva
- Tre differenti livelli di potenza in avvitamento
- Scarico dell'aria attraverso l'impugnatura
- Silenziato



350x305x86 mm  
720LC 17-19-21 mm



1,9 kg

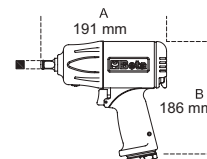

Velocità libera	giri/min	7.000
Massa battente		Doppio martello
Coppia massima	Nm	1.020
Capacità vite/dado	Cl 8.8	M22●34 mm
Capacità vite/dado	Cl 12.9	M18●27 mm
Attacco aria	GAS	1/4"
Pressione di utilizzo	Bar	6,2
Ø tubo consigliato	mm	10
Consumo aria medio	l/min	130



# 1927P



019270008

~~€ 405,00~~ € 234,00

**Avvitatore reversibile in materiale composito**

- Meccanismo impulsivo doppio martello
- Leggero e bilanciato per un facile utilizzo
- Comando d'inversione a leva
- Tre differenti livelli di potenza in avvitamento
- Scarico dell'aria attraverso l'impugnatura
- Impugnatura antivibrazioni



**SUPER POTENTE 1750 NM**

2 kg

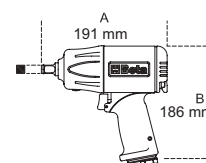

Velocità libera	giri/min	7.500
Massa battente		Doppio Martello
Coppia massima	Nm	1.750
Capacità vite/dado	Cl 8.8	M24●36 mm
Capacità vite/dado	Cl 12.9	M20●30 mm
Attacco aria	GAS	1/4"
Pressione di utilizzo	Bar	6,2
Ø tubo consigliato	mm	10
Consumo aria medio	l/min	290





## 1928K4

3/4"



019280104

**Assortimento di un avvitatore reversibile e 4 bussole Macchina serie lunga, in valigetta di plastica**

- Meccanismo multiplo "Pin Clutch"
- Tre differenti livelli di potenza in avvitamento e svitamento
- Impugnatura antiscivolo
- Comando d'inversione a leva
- Scarico dell'aria attraverso l'impugnatura

5,2 kg



~~€ 655,00~~ € 376,00

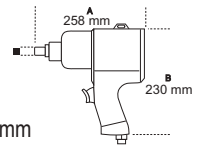

410x330x106 mm

Velocità libera	giri/min	4.000
Massa battente		Pin Clutch
Coppia massima	Nm	1.493
Capacità vite/dado	Cl 8.8	M27●41mm
Capacità vite/dado	Cl 12.9	M24●36mm
Attacco aria	GAS	3/8"
Pressione di utilizzo	Bar	6,2
Ø tubo consigliato	mm	10
Consumo aria medio	l/min	260

728L 27-30-32-36 mm



## 1928DA

3/4"



019280022

**Avvitatore reversibile**

- Meccanismo impulsivo doppio martello
- Robusto e compatto, dotato di un'elevata coppia
- Comando d'inversione a leva
- Tre differenti livelli di potenza in avvitamento e svitamento
- Scarico dell'aria attraverso l'impugnatura
- Impugnatura ergonomica antiscivolo

4,3 kg



~~€ 634,00~~ € 365,00

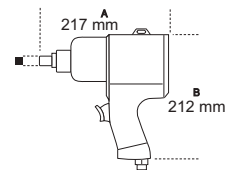

Velocità libera	giri/min	5.000
Massa battente		Doppio martello
Coppia massima	Nm	1.695
Capacità vite/dado	Cl 8.8	M27●41mm
Capacità vite/dado	Cl 12.9	M24●36mm
Attacco aria	GAS	3/8"
Pressione di utilizzo	Bar	6,2
Ø tubo consigliato	mm	10
Consumo aria medio	l/min	240



## 1928CD

3/4"



019280007

**Avvitatore reversibile in materiale composito**

- Meccanismo impulsivo doppio martello
- Elevato rapporto peso/potenza
- Comando d'inversione a leva
- Tre differenti livelli di potenza in avvitamento
- Scarico dell'aria attraverso l'impugnatura
- Silenziato

3,5 kg



~~€ 820,00~~ € 472,00

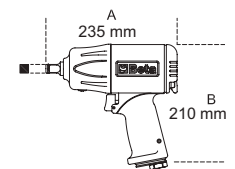

Velocità libera	giri/min	4.500
Massa battente		Doppio martello
Coppia massima	Nm	1.800
Capacità vite/dado	Cl 8.8	M27●41mm
Capacità vite/dado	Cl 12.9	M24●36mm
Attacco aria	GAS	3/8"
Pressione di utilizzo	Bar	6,2
Ø tubo consigliato	mm	10
Consumo aria medio	l/min	215



# 1930A Novità



019300036

€ 965,00 € 555,00

## Avvitatore reversibile

- Meccanismo impulsivo doppio martello
- Dotato di maniglia ausiliaria
- Comando d'inversione a leva
- Tre differenti livelli di potenza in avvitamento
- Scarico dell'aria posto nella parte superiore del corpo

9,5 kg

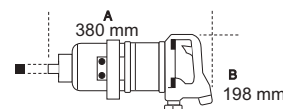

Velocità libera	giri/min	4.000
Massa battente		Doppio martello
Coppia massima	Nm	<b>2.445</b>
Capacità vite/dado	Cl 8.8	M36●55mm
Capacità vite/dado	Cl 12.9	M30●46mm
Attacco aria	GAS	3/8"
Pressione di utilizzo	Bar	6,2
Ø tubo consigliato	mm	13
Consumo aria medio	l/min	460



# 1930PA



019300032

€ 955,00 € 549,00

## Avvitatore reversibile

- Estremamente compatto
- Dotato di maniglia ausiliaria
- Comando d'inversione a leva
- Tre differenti livelli di potenza in avvitamento e svitamento
- Scarico dell'aria attraverso l'impugnatura

9,6 kg

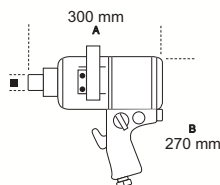
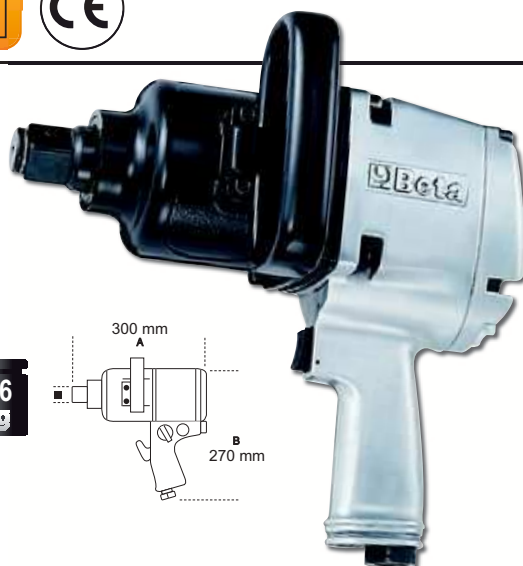

Velocità libera	giri/min	3.500
Massa battente		Doppio martello
Coppia massima	Nm	<b>2445</b>
Capacità vite/dado	Cl 8.8	M36●55mm
Capacità vite/dado	Cl 12.9	M30●46mm
Attacco aria	GAS	1/2"
Pressione di utilizzo	Bar	6,2
Ø interno tubo aria	mm	13
Consumo aria medio	l/min	350

# 1930HLA



019300040

€ 1.395,00 € 805,00

## Avvitatore reversibile

- Dotato di maniglia ausiliaria
- Comando d'inversione a leva
- Tre differenti livelli di potenza in avvitamento
- Scarico dell'aria posto nella parte superiore del corpo

16,4 kg

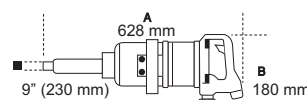

Velocità libera	giri/min	3.000
Massa battente		Doppio martello
Coppia massima	Nm	<b>3661</b>
Capacità vite/dado	Cl 8.8	M42●65mm
Capacità vite/dado	Cl 12.9	M33●50mm
Attacco aria	GAS	1/2"
Pressione di utilizzo	Bar	6,2
Ø interno tubo aria	mm	13
Consumo aria medio	l/min	460

**ALTA COPPIA  
3661 NM**



**19211** **12"** **CE**

019210035

## Cricchetto reversibile a coppia elevata

- Meccanismo impulsivo "Pin Clutch"
- Coppia elevata
- Coppia di reazione notevolmente ridotta
- Molto più rapido dei cricchetti convenzionali
- Impugnatura ergonomica in gomma
- Scarico posteriore dell'aria
- Scarico dell'aria attraverso l'impugnatura

~~€ 268,00~~ € 155,00



1,3 kg

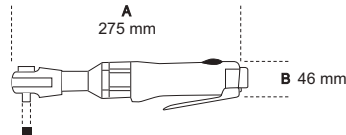

Velocità libera	giri/min	400
Massa battente		Pin Clutch
Coppia massima	Nm	101
Capacità vite/dado	Cl 8.8	M10●16mm
Capacità vite/dado	Cl 12.9	M8●13mm
Attacco aria	GAS	1/4"
Pressione di utilizzo	Bar	6,2
Ø interno tubo aria	mm	10
Consumo aria medio	l/min	235

**1946C4,8**

**CE**

019460006

## Rivettatrice con aspirazione automatica

- Per impiego con rivetti in acciaio, acciaio inox, alluminio e rame, da 2,4 - 3,2 - 4,0 - 4,8 mm
- Becco conico a punta
- Potente e maneggevole, con impugnatura in composito
- Completa di serbatoio portasteli e siringa per la lubrificazione

~~€ 479,00~~ € 275,00



1,5 kg

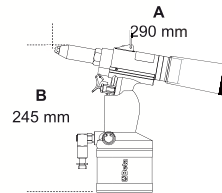

Materiale/rivetto	2,4	3,2	4	4,8
Rame	✓	✓	✓	✓
Alluminio	✓	✓	✓	✓
Acciaio	✓	✓	✓	✓
Acciaio Inox	✓	✓	✓	✓

Potenza di trazione	N	8.900
Lunghezza della corsa	mm	15
Capacità massima rivetti	Ø acciaio inox	4,8 mm
Attacco aria	GAS	1/4"
Pressione di utilizzo	Bar	6,2
Ø interno tubo aria	mm	10
Consumo aria	l/ciclo	2,6



**1932B13**

**Ø13** **CE**

019320004

## Trapano reversibile

- Potente e robusto
- Mandrino di precisione autoserrante
- Dotato di maniglia ausiliaria
- Invertitore di rotazione a leva
- Impugnatura antiscivolo
- Scarico dell'aria attraverso l'impugnatura

~~€ 209,00~~ € 120,00



**400 GIRI/MIN**

1,6 kg

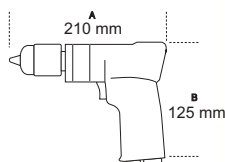

Velocità libera	giri/min	400
Capacità mandrino	mm	1,5÷13
Potenza	kW	0,34
Filettatura albero		1/2" -20UNC
Attacco aria	GAS	1/4"
Pressione di utilizzo	Bar	6,2
Ø interno tubo aria	mm	10
Consumo aria medio	l/min	180



# 1933I

019330005

~~€ 120,00~~ € 69,00

## Smerigliatrice assiale

- Indicata per lavori gravosi e prolungati grazie all'elevata potenza
- Corpo ed impugnatura in materiale antiscivolo
- Montata su cuscinetti a sfera
- Regolatore di velocità mediante manopola
- Attacco aria girevole
- Scarico dell'aria posteriore silenziato
- Leva di sicurezza a scatto
- Fornita con pinza da 3 e 6 mm

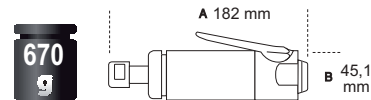

Velocità libera	giri/min	20.000
Capacità pinza	mm	3-6
Potenza	kW	0,38
Attacco aria	GAS	1/4"
Pressione di utilizzo	Bar	6,2
Ø interno tubo aria	mm	10
Consumo aria medio	l/min	260

# 1942A

019420000

~~€ 249,00~~ € 144,00

## Seghetto alternativo

- Potente e maneggevole
- Ideale per tagliare carrozzerie, scarichi e marmitte, alluminio e plastica
- Dotato di impugnatura in gomma, tubo di scarico in PVC e tubo di alimentazione raccordato
- Scarico dell'aria posteriore

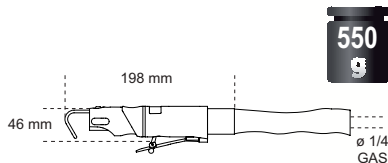

Corse al minuto		10.000
Lunghezza della corsa	mm	10
Attacco aria	GAS	1/4"
Pressione di utilizzo	Bar	6,2
Ø interno tubo aria	mm	8
Consumo aria medio	l/min	75

# 1937

019370001

~~€ 365,00~~ € 211,00

## Levigatrice rotorbitale palmare senza lubrificazione in composito

- Non necessita di lubrificazione
- Estremamente compatta e maneggevole
- Diametro orbita 5 mm
- Platorello con velcro a 6 fori
- Regolazione in continuo della velocità del motore
- Impugnatura in morbido materiale antiscivolo
- Predisposta per la connessione a sistemi di aspirazione con raccordo girevole
- Scarico dell'aria orientabile

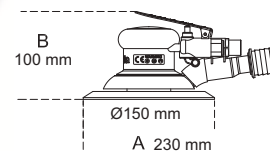

Velocità libera	giri/min	12.000
Potenza	kW	0,18
Dimensione platorello	mm	150
Diametro orbita	mm	5
Filettatura albero		5/16"-24
Attacco aria	GAS	1/4"
Pressione di utilizzo	Bar	6,2
Ø interno tubo aria	mm	10
Consumo aria medio	l/min	170

## 1949M **Novità**

019490400

### Misuratore di pressione per pneumatici

- Pressione di lettura: 0÷4 bar (5÷60 psi)
- Accuratezza: 0,1 bar (1,0 psi)
- Funzione di solo misurazione della pressione
- Funzione di scarico pressione
- Manometro rivestito in gomma antiurto
- Lunghezza del tubo: 350 mm



~~€ 55,00~~ € 31,90

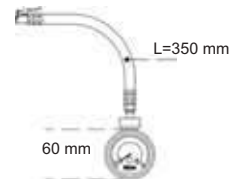

280 g

## 1949GPE

019490008

### Pistola per gonfiaggio pneumatici

- Pressione di esercizio: 0÷11 bar (10÷160 psi)
- Funzione di scarico pressione
- Funzione di solo misurazione della pressione
- Manometro rivestito in gomma antiurto
- Rotazione del tubo a 360°



~~€ 101,00~~ € 58,00

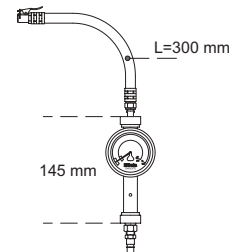

640 g

## 1901T/10



019010210

### Avvolgitubo automatico corpo in materiale plastico antiurto per aria compressa o acqua fredda

- Pressione di utilizzo massima 15 Bar
- Tubo in pvc, Ø 10 mm
- Staffa di fissaggio metallica, orientabile
- Dispositivo automatico di arresto del tubo alla lunghezza desiderata



~~€ 245,00~~ € 141,00



6,5 kg

Attacco aria	GAS	3/8"
Lunghezza tubo	m	15+1
Pressione massima	Bar	15

## 1901BM/8



019010111

### Avvolgitubo automatico corpo in materiale plastico antiurto per aria compressa o acqua fredda

- Pressione di utilizzo max 12 Bar
- Tubo in poliuretano da 9+1 metri, Ø 8 mm

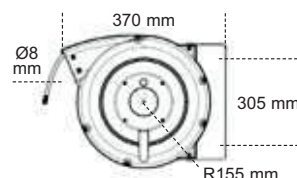

~~€ 208,00~~ € 120,00

Attacco aria	GAS	1/4"
Lunghezza tubo	m	9+1
Pressione massima	Bar	12



3,5 kg

## Scarpe in pelle idrorepellente con lamina antiperforazione

- Puntale in acciaio
- Lamina antiperforazione in acciaio elastico

### 7241C

~~€ 39,00~~ € 22,30



EU	UK	
35	2,5	072410535
36	3,5	072410536
37	4,5	072410537
38	5	072410538
39	6	072410539
40	6,5	072410540
41	7	072410541
42	8	072410542
43	9	072410543
44	10	072410544
45	10,5	072410545
46	11	072410546
47	12	072410547
48	13	072410548



**BASSA**

EN ISO  
20345  
2011

S3 SRC

### 7243C

~~€ 40,00~~ € 22,80



EU	UK	
35	2,5	072430335
36	3,5	072430336
37	4,5	072430337
38	5	072430338
39	6	072430339
40	6,5	072430340
41	7	072430341
42	8	072430342
43	9	072430343
44	10	072430344
45	10,5	072430345
46	11	072430346
47	12	072430347
48	13	072430348

**RAPIDO  
SFILAMENTO**



**ALTA**

EN ISO  
20345  
2011

S3 RS SRC

### 7246B

~~€ 39,50~~ € 22,50

Scarpe in pelle  
scamosciata, traforate

- Puntale in acciaio
- Lamina antiperforazione in acciaio elastico

EU	UK	
35	2,5	072460235
36	3,5	072460236
37	4,5	072460237
38	5	072460238
39	6	072460239
40	6,5	072460240
41	7	072460241
42	8	072460242
43	9	072460243
44	10	072460244
45	10,5	072460245
46	11	072460246
47	12	072460247
48	13	072460248



EN ISO  
20345  
2011

S1P SRC

### 7245B

~~€ 46,50~~ € 26,50

Scarpe "saldatore" stringate  
in pelle idrorepellente  
con rapido sfilamento  
e protezione frontale  
con chiusura a strappo

- Puntale in acciaio
- Lamina antiperforazione in acciaio elastico

EU	UK	
35	2,5	072450235
36	3,5	072450236
37	4,5	072450237
38	5	072450238
39	6	072450239
40	6,5	072450240
41	7	072450241
42	8	072450242
43	9	072450243
44	10	072450244
45	10,5	072450245
46	11	072450246
47	12	072450247
48	13	072450248

**RAPIDO  
SFILAMENTO**



EN ISO  
20345  
2011

S3 RS SRC



# Calzature di sicurezza

## Scarpe in pelle scamosciata con inserti in mesh

- Puntale in acciaio
- Lamina antiperforazione in acciaio elastico

### 7248G

~~€ 48,50~~ € 27,90



EU	UK	
35	2,5	072480135
36	3,5	072480136
37	4,5	072480137
38	5	072480138
39	6	072480139
40	6,5	072480140
41	7	072480141
42	8	072480142
43	9	072480143
44	10	072480144
45	10,5	072480145
46	11	072480146
47	12	072480147
48	13	072480148



BASSA



EN ISO  
20345  
2011

S1P SRC

### 7249G

~~€ 50,00~~ € 28,70



EU	UK	
35	2,5	072490135
36	3,5	072490136
37	4,5	072490137
38	5	072490138
39	6	072490139
40	6,5	072490140
41	7	072490141
42	8	072490142
43	9	072490143
44	10	072490144
45	10,5	072490145
46	11	072490146
47	12	072490147
48	13	072490148



ALTA

## Scarpe in action nabuk idrorepellente con inserti in nylon

- Puntale in acciaio
- Lamina antiperforazione in acciaio elastico

### 7235B

~~€ 60,50~~ € 34,90



EU	UK	
35	2,5	072350235
36	3,5	072350236
37	4,5	072350237
38	5	072350238
39	6	072350239
40	6,5	072350240
41	7	072350241
42	8	072350242
43	9	072350243
44	10	072350244
45	10,5	072350245
46	11	072350246
47	12	072350247
48	13	072350248



BASSA



EN ISO  
20345  
2011

S3 SRC

### 7236B

~~€ 63,00~~ € 36,50



EU	UK	
35	2,5	072360235
36	3,5	072360236
37	4,5	072360237
38	5	072360238
39	6	072360239
40	6,5	072360240
41	7	072360241
42	8	072360242
43	9	072360243
44	10	072360244
45	10,5	072360245
46	11	072360246
47	12	072360247
48	13	072360248



ALTA

**Scarpe in pelle idrorepellente con inserti in nylon, copripuntale di rinforzo in poliuretano ed inserto rifrangente sul tallone**  
 • Punta in acciaio • Lamina antiperforazione in fibra composita

## 7220PE

~~€ 49,00~~ € 28,40



EU	UK	
35	2,5	072200135
36	3,5	072200136
37	4,5	072200137
38	5	072200138
39	6	072200139
40	6,5	072200140
41	7	072200141
42	8	072200142
43	9	072200143
44	10	072200144
45	10,5	072200145
46	11	072200146
47	12	072200147
48	13	072200148



BASSA

EN ISO 20345 2011

S3 SRC

## 7221PE

~~€ 50,50~~ € 29,30



EU	UK	
35	2,5	072210135
36	3,5	072210136
37	4,5	072210137
38	5	072210138
39	6	072210139
40	6,5	072210140
41	7	072210141
42	8	072210142
43	9	072210143
44	10	072210144
45	10,5	072210145
46	11	072210146
47	12	072210147
48	13	072210148

RAPIDO SFILAMENTO



ALTA

EN ISO 20345 2011

S3 RS SRC

Sebring

## 7224PE

~~€ 51,00~~ € 29,50

Scarpe in pelle scamosciata traforata con inserti in nylon, copripuntale di rinforzo in poliuretano ed inserto rifrangente sul tallone

- Punta in acciaio
- Lamina antiperforazione in fibra composita

EU	UK	
35	2,5	072240135
36	3,5	072240136
37	4,5	072240137
38	5	072240138
39	6	072240139
40	6,5	072240140
41	7	072240141
42	8	072240142
43	9	072240143
44	10	072240144
45	10,5	072240145
46	11	072240146
47	12	072240147
48	13	072240148



EN ISO 20345 2011

S1P SRC

Jarama

## 7243CR Novità

~~€ 54,00~~ € 30,90

Scarpe alte in pelle idrorepellente con suola in gomma ad alta resistenza e rapido sfilamento

- Punta in acciaio
- Lamina antiperforazione in acciaio elastico

EU	UK	
35	2,5	072430735
36	3,5	072430736
37	4,5	072430737
38	5	072430738
39	6	072430739
40	6,5	072430740
41	7	072430741
42	8	072430742
43	9	072430743
44	10	072430744
45	10,5	072430745
46	11	072430746
47	12	072430747
48	13	072430748



RAPIDO SFILAMENTO  
SUOLA IN GOMMA



EN ISO 20345 2011

S3 RS HRO SRC



# Calzature di sicurezza

Scarpe in pelle pieno fiore idrorepellente con inserti  
in pelle scamosciata idrorepellente

- Puntale in composito
- Lamina antiperforazione in fibra composita

## 7200PN

~~€ 69,50~~ € 39,90



EU	UK	
35	2,5	072000535
36	3,5	072000536
37	4,5	072000537
38	5	072000538
39	6	072000539
40	6,5	072000540
41	7	072000541
42	8	072000542
43	9	072000543
44	10	072000544
45	10,5	072000545
46	11	072000546
47	12	072000547
48	13	072000548



BASSA

EN ISO  
20345  
2011

S3 SRC

## 7201PN

~~€ 71,50~~ € 40,90

RAPIDO  
SFILAMENTO



EU	UK	
35	2,5	072010535
36	3,5	072010536
37	4,5	072010537
38	5	072010538
39	6	072010539
40	6,5	072010540
41	7	072010541
42	8	072010542
43	9	072010543
44	10	072010544
45	10,5	072010545
46	11	072010546
47	12	072010547
48	13	072010548



ALTA

EN ISO  
20345  
2011

S3 RS SRC

Imola

## Scarpe in pelle scamosciata traforata

- Puntale in composito
- Lamina antiperforazione in fibra composita

## 7210PB

~~€ 64,50~~ € 36,90

Misano



EU	UK	
35	2,5	072100435
36	3,5	072100436
37	4,5	072100437
38	5	072100438
39	6	072100439
40	6,5	072100440
41	7	072100441
42	8	072100442
43	9	072100443
44	10	072100444
45	10,5	072100445
46	11	072100446
47	12	072100447
48	13	072100448

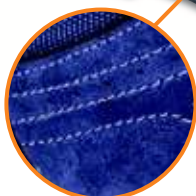

EN ISO  
20345  
2011

S1P SRC

## 7211PG

~~€ 64,50~~ € 36,90

Mugello



EU	UK	
35	2,5	072110435
36	3,5	072110436
37	4,5	072110437
38	5	072110438
39	6	072110439
40	6,5	072110440
41	7	072110441
42	8	072110442
43	9	072110443
44	10	072110444
45	10,5	072110445
46	11	072110446
47	12	072110447
48	13	072110448





## Scarpe in pelle scamosciata con inserti in nylon mesh e PU

- Puntale in fibra di vetro
- Lamina antiperforazione in fibra composita

### 7313G

~~€ 75,50~~ € 43,20



EU	UK	
35	2,5	073130635
36	3,5	073130636
37	4,5	073130637
38	5	073130638
39	6	073130639
40	6,5	073130640
41	7	073130641
42	8	073130642
43	9	073130643
44	10	073130644
45	10,5	073130645
46	11	073130646
47	12	073130647
48	13	073130648



### 7313B

~~€ 75,50~~ € 43,20



EU	UK	
35	2,5	073130835
36	3,5	073130836
37	4,5	073130837
38	5	073130838
39	6	073130839
40	6,5	073130840
41	7	073130841
42	8	073130842
43	9	073130843
44	10	073130844
45	10,5	073130845
46	11	073130846
47	12	073130847
48	13	073130848



EN ISO  
20345  
2011

S1P SRC

**Monza**

## Scarpe in pelle scamosciata idrorepellente con inserto in microfibra

- Puntale in fibra di vetro
- Lamina antiperforazione in fibra composita

### 7316N

~~€ 86,50~~ € 49,50

**Assen**

EU	UK	
35	2,5	073160535
36	3,5	073160536
37	4,5	073160537
38	5	073160538
39	6	073160539
40	6,5	073160540
41	7	073160541
42	8	073160542
43	9	073160543
44	10	073160544
45	10,5	073160545
46	11	073160546
47	12	073160547
48	13	073160548



### 7320M

~~€ 86,50~~ € 49,50

**Estoril**

EU	UK	
35	2,5	073200335
36	3,5	073200336
37	4,5	073200337
38	5	073200338
39	6	073200339
40	6,5	073200340
41	7	073200341
42	8	073200342
43	9	073200343
44	10	073200344
45	10,5	073200345
46	11	073200346
47	12	073200347
48	13	073200348



EN ISO  
20345  
2011

S3 SRC

# Calzature di sicurezza

## Scarpe in pelle scamosciata con inserti in nylon

- Puntale in composito
- Lamina antiperforazione in fibra composita

### 7250NKK

~~€ 93,00~~ € 53,00



EU	UK	
38	5	072500238
39	6	072500239
40	6,5	072500240
41	7	072500241
42	8	072500242
43	9	072500243
44	10	072500244
45	10,5	072500245
46	11	072500246
47	12	072500247



BASSA



EN ISO 20345 2011

S1P SRC

**Sevang**

### 7251NKK

~~€ 98,00~~ € 55,90



EU	UK	
38	5	072510238
39	6	072510239
40	6,5	072510240
41	7	072510241
42	8	072510242
43	9	072510243
44	10	072510244
45	10,5	072510245
46	11	072510246
47	12	072510247



ALTA

## Scarpe in pelle scamosciata idrorepellente con inserti in nylon idrorepellente

- Puntale in composito
- Lamina antiperforazione in fibra composita

### 7258NKK

~~€ 97,00~~ € 55,30



EU	UK	
38	5	072580138
39	6	072580139
40	6,5	072580140
41	7	072580141
42	8	072580142
43	9	072580143
44	10	072580144
45	10,5	072580145
46	11	072580146
47	12	072580147



BASSA



EN ISO 20345 2011

S3 SRC

**Le Mans**

### 7259NKK

~~€ 101,00~~ € 57,50



EU	UK	
38	5	072590138
39	6	072590139
40	6,5	072590140
41	7	072590141
42	8	072590142
43	9	072590143
44	10	072590144
45	10,5	072590145
46	11	072590146
47	12	072590147



ALTA



## 7361UB

~~€ 87,00~~ € 49,90

Scarpe basse in pelle scamosciata traforata con inserti in tessuto canvas traspirante

- Puntaletto in composito
- Lamina antiperforazione in fibra composita

EU	UK	
35	2,5	073610235
36	3,5	073610236
37	4,5	073610237
38	5	073610238
39	6	073610239
40	6,5	073610240
41	7	073610241
42	8	073610242
43	9	073610243
44	10	073610244
45	10,5	073610245
46	11	073610246
47	12	073610247
48	13	073610248



EN ISO 20345 2011

S1P SRC **Kyalami**

## 7360UN

~~€ 91,00~~ € 52,50

Scarpe basse in pelle scamosciata idrorepellente

- Puntaletto in composito
- Lamina antiperforazione in fibra composita

EU	UK	
35	2,5	073600335
36	3,5	073600336
37	4,5	073600337
38	5	073600338
39	6	073600339
40	6,5	073600340
41	7	073600341
42	8	073600342
43	9	073600343
44	10	073600344
45	10,5	073600345
46	11	073600346
47	12	073600347
48	13	073600348



EN ISO 20345 2011

S3 SRC **Pergusa**

Scarpe alte in pelle scamosciata idrorepellente  
Collare in morbido tessuto con imbottitura paramalleolo

- Puntaletto in composito
- Lamina antiperforazione in fibra composita

## 7368UN

~~€ 95,50~~ € 54,90



EU	UK	
35	2,5	073680335
36	3,5	073680336
37	4,5	073680337
38	5	073680338
39	6	073680339
40	6,5	073680340
41	7	073680341
42	8	073680342
43	9	073680343
44	10	073680344
45	10,5	073680345
46	11	073680346
47	12	073680347
48	13	073680348



EN ISO 20345 2011

S3 SRC

**Monaco**

## 7368UM

~~€ 95,50~~ € 54,90



EU	UK	
35	2,5	073680535
36	3,5	073680536
37	4,5	073680537
38	5	073680538
39	6	073680539
40	6,5	073680540
41	7	073680541
42	8	073680542
43	9	073680543
44	10	073680544
45	10,5	073680545
46	11	073680546
47	12	073680547
48	13	073680548





Scarpe in tessuto mesh ad alta traspirazione con inserti in PU Alta Frequenza e rinforzo protettivo del puntale in crosta scamosciata

- Puntale in alluminio • Lamina antiperforazione in fibra composita
- Sistema di chiusura FixLock, semplifica la calzata e lo sfilamento della scarpa (in dotazione anche stringhe tradizionali)

## 7340B

~~€ 125,00~~ € 71,00

FIT PRO NET 

EU	UK	
36	3,5	073400236
37	4,5	073400237
38	5	073400238
39	6	073400239
40	6,5	073400240
41	7	073400241
42	8	073400242
43	9	073400243
44	10	073400244
45	10,5	073400245
46	11	073400246
47	12	073400247



 470 g

EN ISO 20345 2011

S1P SRC

## 7340Y

~~€ 125,00~~ € 71,00

FIT PRO NET 

EU	UK	
36	3,5	073400336
37	4,5	073400337
38	5	073400338
39	6	073400339
40	6,5	073400340
41	7	073400341
42	8	073400342
43	9	073400343
44	10	073400344
45	10,5	073400345
46	11	073400346
47	12	073400347



 470 g

## 7341N FIT PRO

~~€ 132,00~~ € 75,00

Scarpe in micro pelle scamosciata idrorepellente con inserti in PU Alta Frequenza e rinforzo protettivo del puntale in crosta scamosciata

- Puntale in alluminio
- Lamina antiperforazione in fibra composita
- Sistema di chiusura FixLock, semplifica la calzata e lo sfilamento della scarpa (in dotazione anche stringhe tradizionali)

EU	UK	
36	3,5	073410236
37	4,5	073410237
38	5	073410238
39	6	073410239
40	6,5	073410240
41	7	073410241
42	8	073410242
43	9	073410243
44	10	073410244
45	10,5	073410245
46	11	073410246
47	12	073410247



EN ISO 20345 2011

S3 SRC

 470 g



## 7208WR

~~€ 110,00~~ € 63,50

Scarpe alte in pelle idrorepellente con suola in gomma ad alta resistenza e rapido sfilamento Calzatura WR resistente all'acqua

- Puntale in composito
- Lamina antiperforazione in fibra composita

EU	UK	
38	5	072080238
39	6	072080239
40	6,5	072080240
41	7	072080241
42	8	072080242
43	9	072080243
44	10	072080244
45	10,5	072080245
46	11	072080246
47	12	072080247



TriAl

EN ISO 20345 2011

S3 RS WR HRO SRC



WR

**RAPIDO SFILAMENTO**

## 7816G

~~€ 59,00~~ € 33,90

### Pantaloni da lavoro multitasche

- T/C Canvas, 65% poliestere, 35% cotone, 260 g

XS	078160000
S	078160001
M	078160002
L	078160003
XL	078160004
XXL	078160005
XXXL	078160006



## 7816BL

~~€ 59,00~~ € 33,90

### Pantaloni da lavoro multitasche blu

- T/C Canvas, 260 g

XS	078160100
S	078160101
M	078160102
L	078160103
XL	078160104
XXL	078160105
XXXL	078160106



- Tasche per ginocchiere e fondo gamba rinforzati in poliestere 600D
- Vita più alta nella parte posteriore per maggiore protezione della schiena
- Inserto posteriore elasticizzato per facilitare i movimenti
  - Vita elasticizzata ai lati
- Anello per portachiavi in vita
- Ampie tasche laterali con chiusura a bottoni automatici, una dotata di inserto portabadge
  - Cavallo antistrappo

## 7816ST **Novità** STRETCH

~~€ 49,00~~ € 28,00

**SLIM FIT**

### Pantaloni da lavoro elasticizzati

- T/C Twill 250 g, grigio
- Vita elasticizzata ai lati
- Due ampie tasche anteriori, di cui una con taschino
- Inserti porta ginocchiere



- Due tasche posteriori con chiusura a strappo
- Tascone laterale sinistro con chiusura a strappo, dotato di inserto portabadge
- Tasca porta metro e fascia porta martello
- Cavallo antistrappo

XS	078160200
S	078160201
M	078160202
L	078160203
XL	078160204
XXL	078160205
XXXL	078160206



## 7815N

~~€ 76,00~~ € 43,50

### Pantaloni da lavoro multitasche

- T/C canvas ritorto, 65% poliestere, 35% cotone, 280 g

**YKK**

Little Parts. Big Difference..

XS	078150000
S	078150001
M	078150002
L	078150003
XL	078150004
XXL	078150005
XXXL	078150006





## 7525

~~€ 50,00~~ € 28,50

### Jeans da lavoro elasticizzati

- In 68% cotone denim, 29% poliestere, 3% tessuto elasticizzato, 10 OZ

XS	075250046
S	075250048
M	075250050
L	075250052
XL	075250054
XXL	075250056
XXXL	075250058

**YKK**

Little Parts. Big Difference.



## 7526

~~€ 57,50~~ € 32,80

**SLIM FIT**

### Jeans da lavoro elasticizzati

- 68% Cotone denim, 29% poliestere, 3% tessuto elasticizzato, 10OZ
- Rinforzi in poliestere 600D all'interno delle tasche posteriori e sul fondo gamba
- Tasca porta metro e fascia porta martello
- Cavallo antistrappo

XS	075260046
S	075260048
M	075260050
L	075260052
XL	075260054
XXL	075260056
XXXL	075260058



## 7840BL

~~€ 30,50~~ € 17,50

### Pantaloni da lavoro

- T/C Twill, 65% poliestere, 35% cotone, 245 g
- Tasca laterale sinistro con chiusura a strappo ed inserto porta badge
- Fascia porta martello
- Triple cuciture nei punti di maggiore usura
- Chiusura metal zip
- Due ampie tasche anteriori
- Vita elasticizzata ai lati
- Due tasche posteriori con chiusura a strappo
- Tasca porta metro con inserti porta penne o piccoli utensili



XS	078400100
S	078400101
M	078400102
L	078400103
XL	078400104
XXL	078400105
XXXL	078400106
XXXXL	078400107

## 7849BL

~~€ 33,00~~ € 18,90

### Giacca da lavoro

- T/C Twill, 65% poliestere, 35% cotone, 245 g
- Chiusura frontale con zip, coperta da patta con chiusura a strappo
- Tasca sinistra al petto con chiusura a strappo, dotata di inserto porta badge
- Due Ampie tasche in vita
- Due tasche interne
- Fascia in vita elasticizzata per una migliore vestibilità
- Polsini regolabili con bottoni automatici
- Tasca destra al petto con inserti porta penne o piccoli utensili

XS	078490100
S	078490101
M	078490102
L	078490103
XL	078490104
XXL	078490105
XXXL	078490106
XXXXL	078490107





## 7905E

~~€ 73,50~~ € 42,00

### Tuta da lavoro

- In T/C Canvas, 65% poliestere, 35% cotone, 260 g



XS	079050900
S	079050901
M	079050902
L	079050903
XL	079050904
XXL	079050905
XXXL	079050906
XXXXL	079050907



## 7900E

~~€ 46,50~~ € 26,50

### Pantaloni da lavoro multitasche

- In T/C Canvas, 65% poliestere, 35% cotone, 260 g

XS	079000900
S	079000901
M	079000902
L	079000903
XL	079000904
XXL	079000905
XXXL	079000906
XXXXL	079000907



## 7903E

~~€ 58,00~~ € 33,20

### Salopette da lavoro

- In T/C Canvas, 65% poliestere, 35% cotone, 260 g

XS	079030900
S	079030901
M	079030902
L	079030903
XL	079030904
XXL	079030905
XXXL	079030906
XXXXL	079030907



## 7901E

~~€ 37,50~~ € 21,50

### Bermuda da lavoro

- In T/C Canvas, 65% poliestere, 35% cotone, 260 g

XS	079010900
S	079010901
M	079010902
L	079010903
XL	079010904
XXL	079010905
XXXL	079010906
XXXXL	079010907



## 7907E

~~€ 43,50~~ € 25,00

### Gilet multitasche da lavoro

- In T/C Canvas, 65% poliestere, 35% cotone, 260 g

XS	079070900
S	079070901
M	079070902
L	079070903
XL	079070904
XXL	079070905
XXXL	079070906
XXXXL	079070907



## 7909E

~~€ 51,50~~ € 29,50

### Giacca da lavoro

- In T/C Canvas, 65% poliestere, 35% cotone, 260 g



XS	079090900
S	079090901
M	079090902
L	079090903
XL	079090904
XXL	079090905
XXXL	079090906
XXXXL	079090907

## 7865E

~~€ 67,00~~ € 38,50

### Tuta leggera da lavoro

- T/C twill, 65% poliestere, 35% cotone, 180 g



XS	078650900
S	078650901
M	078650902
L	078650903
XL	078650904
XXL	078650905
XXXL	078650906
XXXXL	078650907



## 7860E

~~€ 43,00~~ € 24,80

### Pantaloni leggeri da lavoro

- T/C twill, 65% poliestere, 35% cotone, 180 g

XS	078600900
S	078600901
M	078600902
L	078600903
XL	078600904
XXL	078600905
XXXL	078600906
XXXXL	078600907



## 7863E

~~€ 52,00~~ € 29,80

### Salopette leggera da lavoro

- T/C twill, 65% poliestere, 35% cotone, 180 g

XS	078630900
S	078630901
M	078630902
L	078630903
XL	078630904
XXL	078630905
XXXL	078630906
XXXXL	078630907



## 7861E

~~€ 35,50~~ € 20,30

### Bermuda leggeri da lavoro

- T/C twill, 65% poliestere, 35% cotone, 180 g

XS	078610900
S	078610901
M	078610902
L	078610903
XL	078610904
XXL	078610905
XXXL	078610906
XXXXL	078610907



## 7867E

~~€ 39,50~~ € 22,50

### Gilet multitasche leggero da lavoro

- T/C twill, 65% poliestere, 35% cotone, 180 g

XS	078670900
S	078670901
M	078670902
L	078670903
XL	078670904
XXL	078670905
XXXL	078670906
XXXXL	078670907



## 7869E

~~€ 46,50~~ € 26,50

### Giacca leggera da lavoro

- T/C twill, 65% poliestere, 35% cotone, 180 g

XS	078690900
S	078690901
M	078690902
L	078690903
XL	078690904
XXL	078690905
XXXL	078690906
XXXXL	078690907



## 7875E

~~€ 67,00~~ € 38,50

### Tuta leggera da lavoro

- T/C twill,  
65% poliestere,  
35% cotone,  
180 g



XS	078750900
S	078750901
M	078750902
L	078750903
XL	078750904
XXL	078750905
XXXL	078750906
XXXXL	078750907

## 7870E

~~€ 43,00~~ € 24,80

### Pantaloni leggeri da lavoro

- T/C twill,  
65% poliestere,  
35% cotone, 180 g

XS	078700900
S	078700901
M	078700902
L	078700903
XL	078700904
XXL	078700905
XXXL	078700906
XXXXL	078700907



## 7873E

~~€ 52,00~~ € 29,80

### Salopette leggera da lavoro

- T/C twill,  
65% poliestere,  
35% cotone, 180 g

XS	078730900
S	078730901
M	078730902
L	078730903
XL	078730904
XXL	078730905
XXXL	078730906
XXXXL	078730907



## 7871E

~~€ 35,50~~ € 20,30

### Bermuda leggeri da lavoro

- T/C twill,  
65% poliestere,  
35% cotone, 180 g

XS	078710900
S	078710901
M	078710902
L	078710903
XL	078710904
XXL	078710905
XXXL	078710906
XXXXL	078710907



## 7877E

~~€ 39,50~~ € 22,50

### Gilet multitasche leggero da lavoro

- T/C twill,  
65% poliestere,  
35% cotone, 180 g

XS	078770900
S	078770901
M	078770902
L	078770903
XL	078770904
XXL	078770905
XXXL	078770906
XXXXL	078770907



## 7879E

~~€ 46,50~~ € 26,50

### Giacca leggera da lavoro

- T/C twill,  
65% poliestere,  
35% cotone, 180 g

XS	078790900
S	078790901
M	078790902
L	078790903
XL	078790904
XXL	078790905
XXXL	078790906
XXXXL	078790907







 **Beta**

[www.beta-tools.it](http://www.beta-tools.it)

**speedUP**  
*Racing Sport*

**50** years in  
motorsports





998015300

8 014230 830940

 **Beta**

**Beta Utensili S.p.A.**  
**Via Volta 18**  
**20845 Sovico (MB)**  
**Tel. 039.2077.1**  
**Fax 039.2010742**  
**[www.beta-tools.it](http://www.beta-tools.it)**

**Promozione valida dal 16/01/2017 al 15/12/2017** Prezzi netti I.V.A. esclusa

Le immagini sono indicative, Beta si riserva il diritto di apportare aggiornamenti e migliorie alla propria gamma produttiva senza alcun preavviso.